

HIMatrix

Safety-Related Controller

F35 03 Manual



HIMA Paul Hildebrandt GmbH + Co KG
Industrial Automation

All HIMA products mentioned in this manual are protected by the HIMA trade-mark. Unless noted otherwise, this also applies to other manufacturers and their respective products referred to herein.

All of the instructions and technical specifications in this manual have been written with great care and effective quality assurance measures have been implemented to ensure their validity. For questions, please contact HIMA directly. HIMA appreciates any suggestion on which information should be included in the manual.

Equipment subject to change without notice. HIMA also reserves the right to modify the written material without prior notice.

For further information, refer to the CD-ROM and our website <http://www.hima.de> and <http://www.hima.com>.

© Copyright 2011, HIMA Paul Hildebrandt GmbH + Co KG

All rights reserved

Contact

HIMA contact details:

HIMA Paul Hildebrandt GmbH + Co KG

P.O. Box 1261

68777 Brühl, Germany

Phone: +49 6202 709-0

Fax: +49 6202 709-107

E-mail: info@hima.com

Revision index	Revisions	Type of Change	
		technical	editorial
1.00	First edition of the manual		

Table of Contents

1	Introduction	7
1.1	Structure and Use of this Manual	7
1.2	Target Audience	7
1.3	Formatting Conventions	8
1.3.1	Safety Notes	8
1.3.2	Operating Tips	9
2	Safety	10
2.1	Intended Use	10
2.1.1	Environmental Requirements	10
2.1.2	ESD Protective Measures	10
2.2	Residual Risk	11
2.3	Safety Precautions	11
2.4	Emergency Information	11
3	Product Description	12
3.1	Safety Function	12
3.1.1	Safety-Related Digital Inputs	12
3.1.1.1	Reaction in the Event of a Fault	13
3.1.1.2	Line Control	13
3.1.2	Safety-Related Digital Outputs	14
3.1.2.1	Reaction in the Event of a Fault	14
3.1.3	Safety-Related Counters	15
3.1.3.1	Reaction in the Event of a Fault	15
3.1.4	Safety-Related Analog Inputs	16
3.1.4.1	Line Monitoring for Digital Outputs	17
3.1.4.2	Reaction in the Event of a Fault	18
3.2	Equipment and Scope of Delivery	19
3.2.1	IP Address and System ID (SRS)	19
3.3	Type Label	19
3.4	Assembly	20
3.4.1	LED Indicators	21
3.4.1.1	Operating Voltage LED	21
3.4.1.2	System LEDs	22
3.4.1.3	Communication LEDs	23
3.4.1.4	I/O LEDs	23
3.4.1.5	Fieldbus LEDs	23
3.4.2	Communication	24
3.4.2.1	Connections for Ethernet Communication	24
3.4.2.2	Network Ports Used for Ethernet Communication	25
3.4.2.3	Connections for Fieldbus Communication	25

3.4.3	Mode of Operation of the Counters	26
3.4.3.1	Counter Function 1 (Depending on the Count Direction Input Signal)	26
3.4.3.2	Counter Function 2 (Irrespective of the Count Direction Input Signal)	26
3.4.3.3	Decoder Operation for Gray Code.....	27
3.4.3.4	Comparing the Codes Used	27
3.4.4	Reset Key	28
3.4.5	Hardware Clock.....	28
3.5	Product Data	29
3.6	Certified HIMatrix F35	31
4	Start-up	32
4.1	Installation and Mounting.....	32
4.1.1	Connecting the Digital Inputs	32
4.1.2	Connecting the Digital Outputs.....	33
4.1.3	Connecting the Counters.....	33
4.1.4	Connecting the Analog Inputs	34
4.1.4.1	Shunt Adapter	35
4.2	Sequence of Events Recording (SOE).....	35
4.3	Configuring the Controller with SILworX.....	36
4.3.1	Processor Module	36
4.3.1.1	Tab: Module	36
4.3.1.2	Tab: Routings	38
4.3.1.3	Tab: Ethernet Switch	38
4.3.1.4	Tab: VLAN (Port-Based VLAN).....	39
4.3.1.5	Tab: LLDP	39
4.3.1.6	Tab: Mirroring	40
4.3.2	Communication Module.....	40
4.3.3	Parameters and Error Codes for the Inputs and Outputs	40
4.3.4	Digital Ountputs F35.....	41
4.3.4.1	Tab: Module	41
4.3.4.2	Tab: DO 8: Channels	42
4.3.5	Counter F35	43
4.3.5.1	Tab: Module	43
4.3.5.2	Tab: HSC 2: Channels	44
4.3.6	Analog and Digital Inputs F35	45
4.3.6.1	Tab: Module	45
4.3.6.2	Tab: MI 24/8: AI-Channels	46
4.3.6.3	Tab: MI 24/8: DI-Channels	47
4.4	Connection Variants.....	48
4.4.1	Wired Mechanical Contacts on Analog Inputs.....	48
4.4.1.1	Switching Thresholds of the Analog Inputs for Mechanical Contacts.....	49
4.4.1.2	Switching Thresholds Used for Monitoring the Supply	49
4.4.2	Wired Mechanical Contacts on Digital Inputs	50
4.4.2.1	Wired Mechanical Contacts With Resistance Values of 2 kΩ and 22 kΩ.....	50
4.4.2.2	Wired Mechanical Contacts with Resistance Values of 2.1 kΩ and 22 kΩ	51

5	Operation	53
5.1	Handling.....	53
5.2	Diagnosis.....	53
6	Maintenance	54
6.1	Faults	54
6.2	Maintenance Measures.....	54
6.2.1	Loading the Operating System	54
6.2.2	Proof Test	54
7	Decommissioning	55
8	Transport	56
9	Disposal	57
	Appendix	59
	Glossary.....	59
	Index of Figures	60
	Index of Tables.....	60
	Index.....	62

1 Introduction

This manual describes the technical characteristics of the device and its use. It provides information on how to install, start up and configure the module in SILworX.

1.1 Structure and Use of this Manual

The content of this manual is part of the hardware description of the HIMatrix programmable electronic system.

This manual is organized in the following main chapters:

- Introduction
- Safety
- Product Description
- Start-up
- Operation
- Maintenance
- Decommissioning
- Transport
- Disposal

Additionally, the following documents must be taken into account:

Name	Content	Document number
HIMatrix System Manual Compact Systems	Hardware description of the HIMatrix compact systems	HI 800 141 E
HIMatrix Safety Manual	Safety functions of the HIMatrix system	HI 800 023 E
HIMatrix Engineering Manual	Project planning description for HIMatrix systems	HI 800 101 E
SILworX Communication Manual	Description of the communication protocols, ComUserTask and their configuration in SILworX	HI 801 101 E
SILworX Online Help	Instructions on how to use SILworX	-
SILworX First Steps	Introduction to SILworX using the HIMax system as an example	HI 801 103 E

Table 1: Additional Relevant Documents

The latest manuals can be downloaded from the HIMA website at www.hima.com. The revision index on the footer can be used to compare the current version of existing manuals with the Internet edition.

1.2 Target Audience

This document addresses system planners, configuration engineers, programmers of automation devices and personnel authorized to implement, operate and maintain the modules and systems. Specialized knowledge of safety-related automation systems is required.

1.3 Formatting Conventions

To ensure improved readability and comprehensibility, the following fonts are used in this document:

Bold:	To highlight important parts Names of buttons, menu functions and tabs that can be clicked and used in the programming tool.
<i>Italics:</i>	For parameters and system variables
Courier	Literal user inputs
RUN	Operating state are designated by capitals
Chapter 1.2.3	Cross references are hyperlinks even though they are not particularly marked. When the cursor hovers over a hyperlink, it changes its shape. Click the hyperlink to jump to the corresponding position.

Safety notes and operating tips are particularly marked.

1.3.1 Safety Notes

The safety notes are represented as described below.

These notes must absolutely be observed to reduce the risk to a minimum. The content is structured as follows:

- Signal word: danger, warning, caution, notice
- Type and source of danger
- Consequences arising from the danger
- Danger prevention

SIGNAL WORD



Type and source of danger!
Consequences arising from the danger
Danger prevention

The signal words have the following meanings:

- Danger indicates hazardous situation which, if not avoided, will result in death or serious injury.
- Warning indicates hazardous situation which, if not avoided, could result in death or serious injury.
- Caution indicates hazardous situation which, if not avoided, could result in minor or modest injury.
- Notice indicates a hazardous situation which, if not avoided, could result in property damage.

NOTE



Type and source of damage!
Damage prevention

1.3.2 Operating Tips

Additional information is structured as presented in the following example:

i

The text corresponding to the additional information is located here.

Useful tips and tricks appear as follows:

TIP

The tip text is located here.

2 Safety

The following safety information, notes and instructions must be strictly observed. The product may only be used if all guidelines and safety instructions are adhered to.

This product is operated with SELV or PELV. No imminent danger results from the product itself. The use in Ex-Zone is permitted if additional measures are taken.

2.1 Intended Use

HIMatrix components are designed for assembling safety-related controller systems.

When using the components in the HIMatrix system, comply with the following general requirements.

2.1.1 Environmental Requirements

Requirement type	Range of values
Protection class	Protection class III in accordance with IEC/EN 61131-2
Ambient temperature	0...+60 °C
Storage temperature	-40...+85 °C
Pollution	Pollution degree II in accordance with IEC/EN 61131-2
Altitude	< 2000 m
Housing	Standard: IP20
Supply voltage	24 VDC

Table 2: Environmental Requirements

Exposing the HIMatrix system to environmental conditions other than those specified in this manual can cause the HIMatrix system to malfunction.

2.1.2 ESD Protective Measures

Only personnel with knowledge of ESD protective measures may modify or extend the system or replace devices.

NOTE



Device damage due to electrostatic discharge!

- When performing the work, make sure that the workspace is free of static, and wear an ESD wrist strap.
- If not used, ensure that the device is protected from electrostatic discharge, e.g., by storing it in its packaging.

2.2 Residual Risk

No imminent danger results from a HIMatrix system itself.

Residual risk may result from:

- Faults in the engineering
- Faults in the user program
- Faults in the wiring

2.3 Safety Precautions

Observe all local safety requirements and use the protective equipment required on site.

2.4 Emergency Information

A HIMatrix system is a part of the safety equipment of a site. If a device or a module fails, the site adopts the safe state.

In case of emergency, no action that may prevent the HIMatrix systems from operating safely is permitted.

3 Product Description

The safety-related **F35 03** controller is a compact system in a metal housing with 24 digital inputs, 8 digital outputs, 2 counters and 8 analog inputs.

Communication is configured using SILworX, see Chapter 4.3.

The device is suitable for sequence of events recording (SOE), see Chapter 4.2. The device supports multitasking and reload. For more details, refer to the System Manual for Compact Systems (HI 800 141 E).

i

A licence is required to use the events recording, the multitasking and the reload features.

The device has been certified by the TÜV for safety-related applications up to SIL 3 (IEC 61508, IEC 61511 and IEC 62061) and PL e (EN ISO 13849-1). Further safety standards, application standards and test standards are specified in the certificate available on the HIMA website.

3.1 Safety Function

The controller is equipped with safety-related digital inputs and outputs, safety-related counters and safety-related analog inputs.

3.1.1 Safety-Related Digital Inputs

The controller is equipped with 24 digital inputs. The state (HIGH, LOW) of each input is signaled by an individual LED.

i

The LEDs for the digital inputs are activated by the program if the F35 is in RUN.

The input signals are captured analogically and made available as INT values from 0...3000 (0...30 V) to the program.

i

The digital inputs must not be used as safety-related analog outputs!

Configurable thresholds are used to generate BOOL values.

The default setting is:

Low level: < 7 V High level: > 13 V

The thresholds are set using system parameters, see Table 41. The thresholds must have a distance of at least 2 V.

Mechanical contacts without own power supply or signal power source can be connected to the inputs. Potential-free mechanical contacts without own power supply are fed via an internal short-circuit-proof 24 V power source (LS+). Each of them supply a group of 8 mechanical contacts. Figure 1 shows how the connection is performed.

With signal voltage sources, the corresponding ground must be connected to the input (L-), see Figure 1.

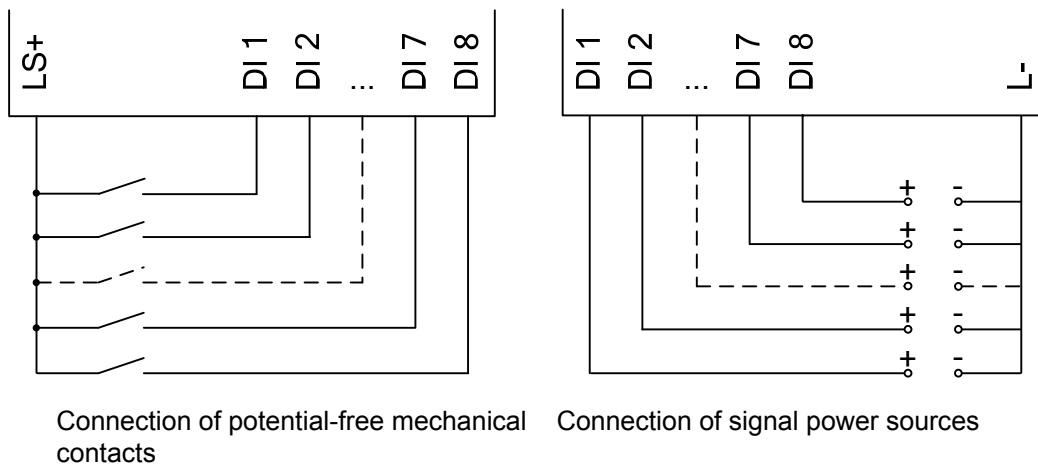

Figure 1: Connections to Safety-Related Digital Inputs

For the external wiring and the connection of sensors, apply the de-energized-to-trip principle. Thus, if a fault occurs, the input signals adopt a de-energized, safe state (low level).

An external wire is not monitored, however, an open-circuit is considered as safe low level.

3.1.1.1 Reaction in the Event of a Fault

If the device detects a fault on a digital input, the user program processes a low level in accordance with the de-energized to trip principle.

The device activates the *FAULT* LED.

In addition to the channel signal value, the user program must also consider the corresponding error code.

The error code allows the user to configure additional fault reactions in the user program.

3.1.1.2 Line Control

The detection of short-circuits and open circuits cannot be configured for the F35 system, e.g., on EMERGENCY STOP inputs complying with Cat. 4 in accordance with EN 954-1.

Line monitoring for digital outputs is possible, see chapter 3.1.4.1.

3.1.2 Safety-Related Digital Outputs

The controller is equipped with 8 digital outputs. The state (HIGH, LOW) of each output is signaled by an individual LED (HIGH, LOW).

At the maximum ambient temperature, each of the outputs 1...3 and 5...7 can be loaded with 0.5 A, and outputs 4 and 8 can be loaded with 1 A or 2 A at an ambient temperature of up to 50 °C.

If an overload occurs, one or all digital outputs are switched off. If the overload is removed, the outputs are switched on again automatically, see Table 21.

The external wire of an output is not monitored, however, a detected short-circuit is signaled.

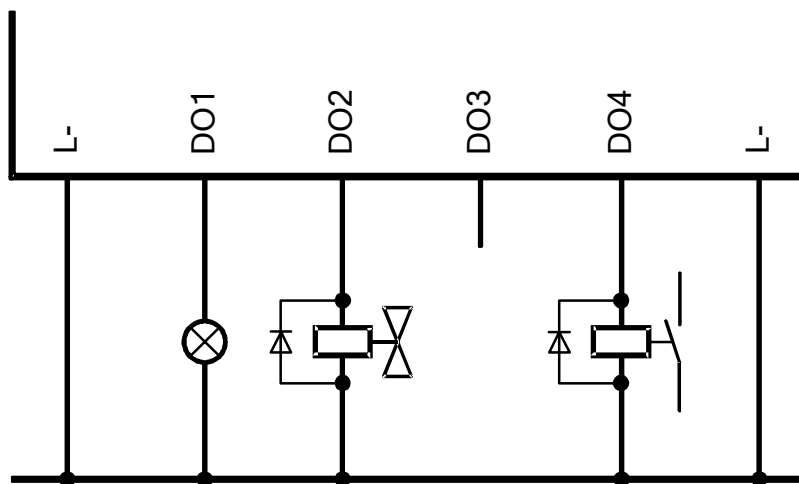

Figure 2: Connection of Actuators to Outputs

The redundant connection of two outputs must be decoupled with diodes.

⚠ WARNING



For connecting a load to a one-pole switching output, use the corresponding L-ground of the respective channel group (two-pole connection) to ensure that the internal protective circuit can function.

Inductive loads may be connected with no free-wheeling diode on the actuator. However, HIMA strongly recommends connecting a protective diode directly to the actuator.

3.1.2.1 Reaction in the Event of a Fault

If the device detects a faulty signal on a digital output, the affected module output is set to the safe (de-energized) state using the safety switches.

If a fault in the device occurs, all digital outputs are switched off.

In both cases, the device activates the *FAULT* LED.

The error code allows the user to configure additional fault reactions in the user program.

3.1.3 Safety-Related Counters

The controller is equipped with 2 independent counters with inputs that can be configured for 5 V or 24 V level.

The required voltage level is determined with the *Counter[0x].5/24V Mode* system parameter.

Input A is the counter input, B is the count direction input and input Z (zero track) is used to reset.

Alternatively, all inputs are 3-bit Gray code inputs (with decoder operation)

The following modes of operation can be implemented:

- Counter Function 1 (Depending on the Count Direction Input Signal)
- Counter Function 2 (Irrespective of the Count Direction Input Signal)
- Decoder operation with attached absolute rotary transducer

Refer to Chapter 3.4.3 for more details on how to configure the counters.

The safety-related counter has a 24-bit resolution, the maximum counter reading is $2^{24} - 1$ (= 16 777 215).

3.1.3.1 Reaction in the Event of a Fault

If the device detects a fault in the counter section, a status bit is set for evaluation in the user program.

The device activates the *FAULT LED*.

In addition to the status bit, the user program must also consider the corresponding error code.

The error code allows the user to configure additional fault reactions in the user program.

3.1.4 Safety-Related Analog Inputs

The controller is equipped with 8 analog inputs with transmitter supplies for the unipolar measurement of voltages of 0...10 V, referenced to L-. With a shunt, also currents of 0...20 mA can be measured.

Input channels	Polarity	Current, voltage	Range of values in the application		Safety-related accuracy
			FS1000 ¹⁾	FS2000 ¹⁾	
8	Unipolar	0...+10 V	0...1000	0...2000	2 %
8	Unipolar	0...20 mA	0...500 ²⁾ 0...1000 ³⁾	0...1000 ²⁾ 0...2000 ³⁾	2 %

¹⁾ can be configured by selecting the type in the programming tool
²⁾ with external Z 7301 shunt adapter, see 4.1.4.1
³⁾ with external Z 7302 shunt adapter, see 4.1.4.1

Table 3: Input Values for the Analog Inputs

The resolution of the voltage and the current values depends on the parameter set in the properties of the controller.

In SILworX, the *FS 1000 / FS 2000* system parameter can be selected in the Module tab (Module of the digital and analog inputs MI 24/8). Depending on the selection, different resolutions result in the user program for the -> *Value [INT]* system parameter, see Chapter 4.3.6.1. To monitor the -> *Value [INT]* parameter, evaluate the corresponding -> *Error Code [BYTE]* fault value in the user program.

The input signals are evaluated in accordance with the de-energized to trip principle.

Only shielded cables with a length of a maximum of 300 m must be connected to the analog inputs. Each analog input must be connected to a twisted pair of wires. The shielding must be connected to the controller and the sensor housing and earthed on one end to the controller side to form a Faraday cage.

Unused analog inputs must be short-circuited.

If an open-circuit occurs during voltage measurement (the line is not monitored), any input signals are processed on the high-resistance inputs. The value resulting from this fluctuating input voltage is not reliable. Therefore with voltage inputs, the channels must be terminated by a 10 kΩ resistor. The internal resistance of the source must be taken into account.

For a current measurement with the shunt connected in parallel, the 10 kΩ resistor is not required.

The analog inputs have a common ground L-.

The analog inputs are designed to retain the metrological accuracy for 10 years. A recalibration must be carried out every 10 years.

3.1.4.1 Line Monitoring for Digital Outputs

The analog inputs can be used to monitor the digital outputs for short-circuits and open-circuits.

Figure 3 shows a circuitry for line monitoring (open-circuits and short-circuits) that complies with SIL 3. Additionally, the S1 supply voltage is monitored via a digital input DI.

In this application, the actuator (e.g., solenoid valve) is connected to the digital output between DO and L-.

All specified electronic components must be directly attached to the clamps.

The reaction to open-circuits and short-circuits must be configured in the user program.

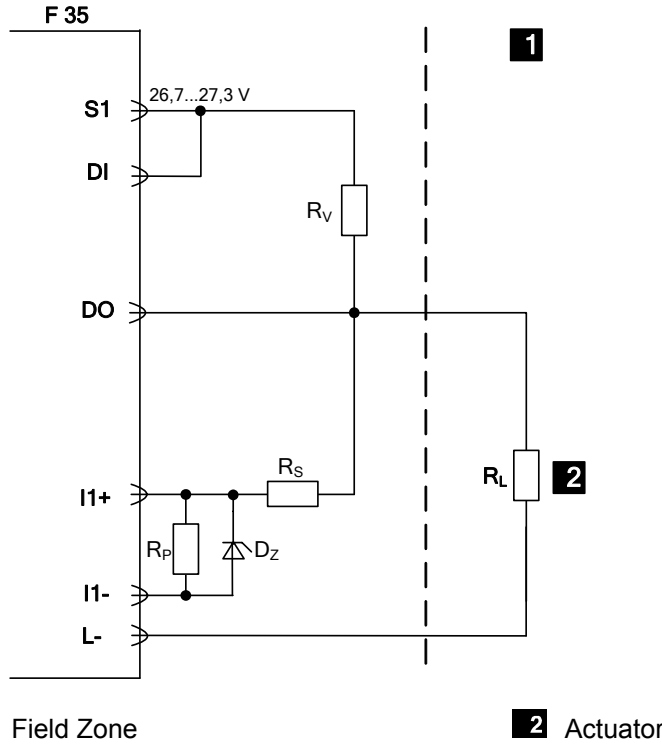

Figure 3: Circuitry for Line Monitoring

Designation	Value	Description
R _V	2.0 kΩ / 0.5 W	Resistor
R _S	2.0 kΩ / 0.5 W	Resistor
R _P	100 kΩ	Resistor
D _Z	11 V ± 5 % / 0.3 W	Z-diode
R _L	75 Ω	Load resistor (e.g. solenoid valve)

Table 4: Values for Circuitry for Line Monitoring

3.1.4.2 Reaction in the Event of a Fault

If the device detects a fault on an analog input, the *AI.Error Code* system parameter > 0 is set. In case of module faults, the *Mod. Error Code* system parameter > 0 is set.

In both cases, the device activates the *FAULT* LED.

In addition to the analog value the error code must be evaluated. The analog value must be configured to ensure a safety-related reaction.

The error code allows the user to configure additional fault reactions in the user program.

3.2 Equipment and Scope of Delivery

The available components and their part numbers are listed below:

Designation	Description	Part no.
F35 03 SILworX	Compact controller with 24 digital inputs, 8 digital outputs, 2 counters and 8 analog inputs, Operating temperature 0...60 °C, for SILworX programming tool	98 2200497

Table 5: Part Numbers

3.2.1 IP Address and System ID (SRS)

A transparent label is delivered with the device to allow one to note the IP addresses of the CPU and COM and the system ID (SRS for system rack slot) after a change.

Default value for IP address of the CPU: 192.168.0.99

Default value for IP address of the COM: 192.168.0.100

Default value for SRS: 60000.0.0

The label must be affixed such that the ventilation slots in the housing are not obstructed.

Refer to the *SILworX* First Steps manual for more information on how to modify the IP address and the system ID.

3.3 Type Label

The type plate contains the following details:

- Product name
- Bar code (1D or 2D code)
- Part no.
- Production year
- Hardware revision index (HW Rev.)
- Firmware revision index (FW Rev.)
- Operating voltage
- Mark of conformity

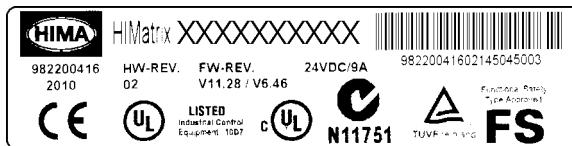

Figure 4: Sample Type Label

3.4 Assembly

This chapter describes the layout and function of the controller, and its connection for communication.

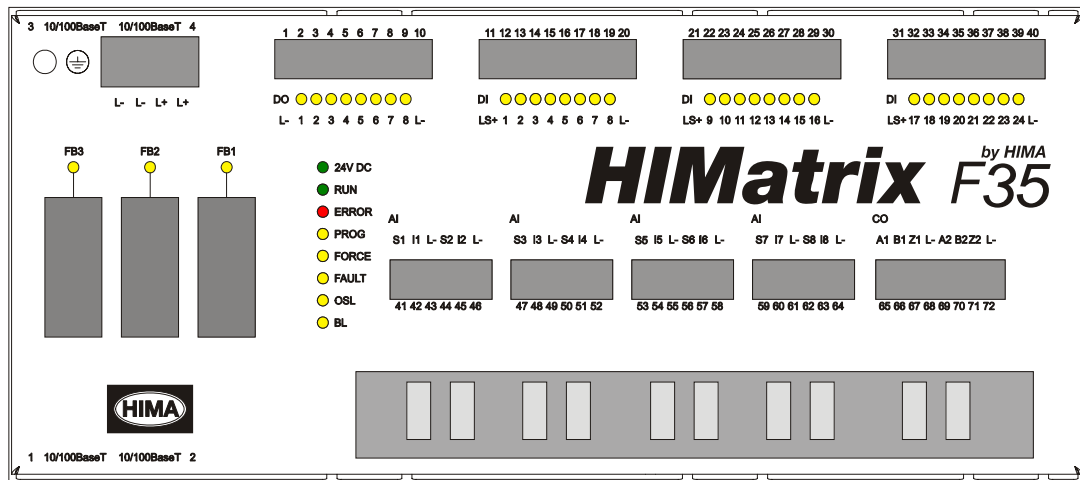
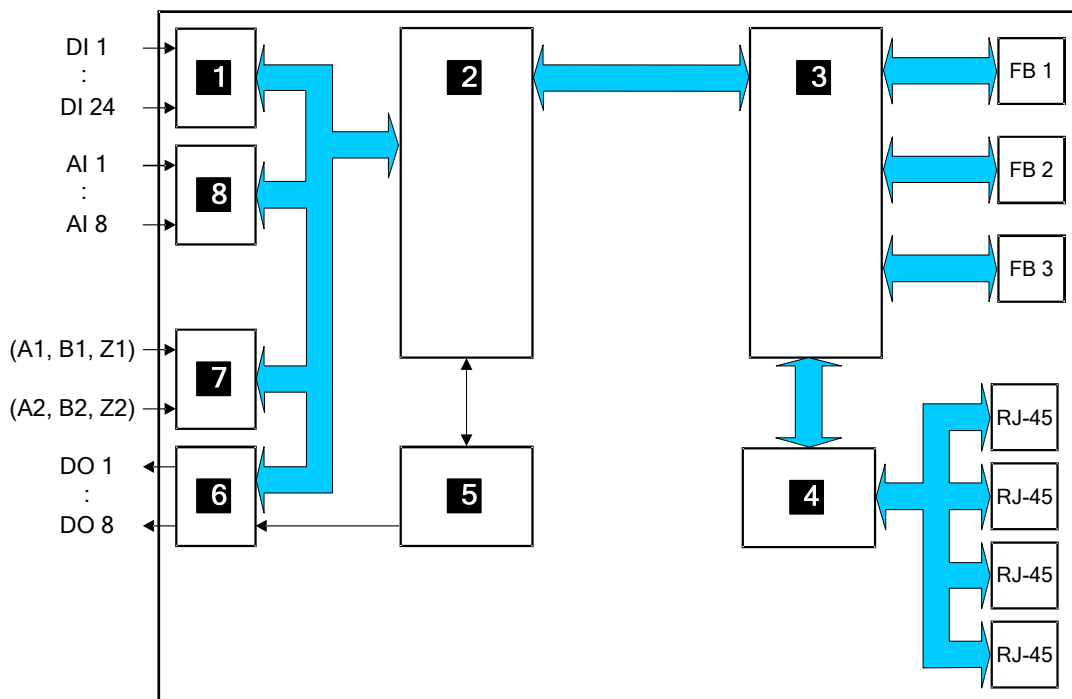

Figure 5: Front View



- | | |
|---|------------------------------|
| 1 Digital Inputs | 5 Watchdog |
| 2 Safety-Related Processor System CPU) | 6 Digital Outputs |
| 3 Communication System (COM) | 7 Counter, 2 Channels |
| 4 Switch | 8 Analog Inputs |

Figure 6: Block Diagram

3.4.1 LED Indicators

The light-emitting diodes (LEDs) indicate the operating state of the controller. The LEDs are classified as follows:

- Operating voltage LED
- System LEDs
- Communication LED
- I/O LEDs
- Fieldbus LEDs

When the supply voltage is switched on, a LED test is performed and all LEDs are briefly lit simultaneously.

Definition of Blinking Frequencies

The following table defines the blinking frequencies of the LEDs:

Name	Blinking frequencies
Blinking1	Long (approx. 600 ms) on, long (approx. 600 ms) off
Blinking-x	Ethernet communication: Blinking in sync with data transfer

Table 6: Blinking Frequencies of LEDs

3.4.1.1 Operating Voltage LED

LED	Color	Status	Description
24 VDC	Green	On	24 VDC operating voltage present
		Off	No operating voltage

Table 7: Operating Voltage LED

3.4.1.2 System LEDs

While the system is being booted, all LEDs are lit simultaneously.

LED	Color	Status	Description
RUN	Green	On	<ul style="list-style-type: none"> Device in RUN, normal operation A loaded user program is being executed.
		Blinking1	<ul style="list-style-type: none"> Device in STOP A new operating system is being loaded.
		Off	The device is not in the RUN state or the STOP state.
ERR	Red	On/Blinking1	<ul style="list-style-type: none"> The device is in the ERROR STOP state Internal module faults detected by self-tests, e.g., hardware, software or voltage supply. The processor system can only be restarted with a command from the PADT (reboot). Fault while loading the operating system
		Off	No faults detected.
PROG	Yellow	On	<ul style="list-style-type: none"> A new configuration is being loaded into the device. WDT or FTT change Check for duplicate IP address SRS change
		Blinking1	<ul style="list-style-type: none"> Reload is being performed A duplicate IP address was detected. ¹⁾ Profinet has received an identify request. ¹⁾
		Off	None of the described events occurred.
FORCE	Yellow	On	Forcing prepared: The force switch is set for a variable, the force main switch is still deactivated. The device is in the RUN or STOP state.
		Blinking1	<ul style="list-style-type: none"> Forcing is active: At least one local or global variable has adopted the corresponding force value. A duplicate IP address was detected. ¹⁾ Profinet has received an identify request. ¹⁾
		Off	None of the described events occurred.
FAULT	Yellow	Blinking1	<ul style="list-style-type: none"> The new operating system is corrupted (after OS download). Fault while loading a new operating system The loaded configuration is defective. One or multiple I/O faults occurred. A duplicate IP address was detected. ¹⁾ Profinet has received an identify request. ¹⁾
		Off	None of the described faults occurred.
OSL	Yellow	Blinking1	<ul style="list-style-type: none"> Operating system emergency loader active. A duplicate IP address was detected. ¹⁾ Profinet has received an identify request. ¹⁾
		Off	None of the described events occurred.
BL	Yellow	Blinking1	<ul style="list-style-type: none"> OS and OSL binary defective or INIT_FAIL hardware fault. Fault in the external process data communication A duplicate IP address was detected. ¹⁾ Profinet has received an identify request. ¹⁾
		Off	None of the described events occurred.

¹⁾ If all the LEDs PROG, FORCE, FAULT, OSL and BL are blinking simultaneously.

Table 8: System LEDs

3.4.1.3 Communication LEDs

All RJ-45 connectors are provided with a small green and a yellow LEDs. The LEDs signal the following states:

LED	Status	Description
Green	On	Full duplex operation
	Blinking1	IP address conflict, all communication LEDs are blinking
	Blinking-x	Collision
	Off	Half duplex operation, no collision
Yellow	On	Connection available
	Blinking1	IP address conflict, all communication LEDs are blinking
	Blinking-x	Interface activity
	Off	No connection available

Table 9: Ethernet Indicators

3.4.1.4 I/O LEDs

LED	Color	Status	Description
DI 1...24	Yellow	On	The related input is active (energized).
		Off	The related input is inactive (de-energized).
DO 1...8	Yellow	On	The related output is active (energized).
		Off	The related output is inactive (de-energized).

Table 10: I/O LEDs

3.4.1.5 Fieldbus LEDs

LEDs FB1...FB3 are used to display the state of communication occurring via the serial interfaces. The function of the LED depends on the used protocol.

Refer to the SILworX Communication Manual (HI 801 101 E) for more details on the function of the LEDs.

3.4.2 Communication

The controller communicates with remote I/Os via **safeethernet**. Up to 128 redundant **safeethernet** connections can be configured.

3.4.2.1 Connections for Ethernet Communication

Property	Description
Port	4 x RJ-45
Transfer standard	10/100 Base-T, half and full duplex
Auto negotiation	Yes
Auto crossover	Yes
IP address	Freely configurable ¹⁾
Subnet Mask	Freely configurable ¹⁾
Supported protocols	<ul style="list-style-type: none"> ▪ Safety-related: safeethernet, PROFIsafe ▪ Standard protocols: Programming and debugging tool (PADT), OPC, Modbus TCP, TCP-SR, SNTP, ComUserTask, PROFINET
¹⁾ The general rules for assigning IP address and subnet masks must be adhered to.	

Table 11: Ethernet Interfaces Properties

Two RJ-45 connectors with integrated LEDs are located on the top and on the bottom left-hand side of the housing. Refer to Chapter 3.4.1.3 for a description of the LEDs' function.

The connection parameters are read based on the MAC address (media access control address) defined during manufacturing.

CPU and COM have their own MAC addresses. The CPU MAC address is specified on a label located above the two RJ-45 connectors (1 and 2).

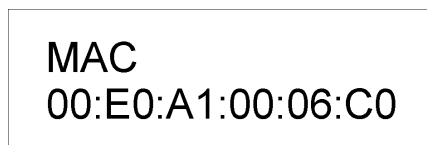

Figure 7: Sample MAC Address Label

The COM MAC address corresponds to the CPU MAC address, except for the last byte which is increased by 1.

Example:

CPU MAC address: 00:E0:A1:00:06:C0

COM MAC address: 00:E0:A1:00:06:C1

The controller is equipped with an integrated switch for Ethernet communication. For further information on the integrated switch and **safeethernet**, refer to Chapter *Communication* of the System Manual for Compact Systems (HI 800 141 E).

3.4.2.2 Network Ports Used for Ethernet Communication

UDP ports	Use
123	SNTP (time synchronization between PES and remote I/O, PES and external devices)
502	Modbus (can be modified by the user)
6010	safeethernet and OPC
6005/ 6012	If TCS_DIRECT was not selected in the HH network
8000	Programming and operation with SILworX
8004	Configuration of the remote I/O using the PES (SILworX)
34964	PROFINET endpoint mapper (required for establishing the connection)
49152	PROFINET RPC server
49153	PROFINET RPC client

Table 12: Network Ports (UDP Ports) in Use

TCP ports	Use
502	Modbus (can be modified by the user)
xxx	TCP SR assigned by the user

Table 13: Network Ports (TCP Ports) in Use

i

The ComUserTask can use any port if it is not already used by another protocol.

3.4.2.3 Connections for Fieldbus Communication

The three 9-pole D-sub connectors are located on the front plate of the housing.

The fieldbus interfaces FB1 and FB2 can be equipped with fieldbus submodules. The fieldbus submodules are optional and must be mounted by the manufacturer. The available fieldbus submodules are described in the SILworX Communication Manual (HI 801 101 E).

The fieldbus interfaces are not operational without fieldbus submodule.

Factory-made, the fieldbus interface FB3 is equipped with RS485 for Modbus (master or slave) or ComUserTask.

3.4.3 Mode of Operation of the Counters

Both counters for the F35 are configured via system variables which are described in Table 38.

The following modes of operation can be implemented:

3.4.3.1 Counter Function 1 (Depending on the Count Direction Input Signal)

Counter[0x].Auto. Advance Sense system variable set to TRUE, counting with falling edge on input A1 (A2).

Low level on count direction input B1 (B2) increments (increases) the counter value,
High level on count direction input B1 (B2) decrements (decreases) the counter value.

For this mode of operation, the Z1 input (Z2) must be set to high level. The counter can be reset with a short-time low level.

Configuration of counter function 1:

System Variable	Description	Value
Counter[0x].5/24V Mode	Inputs	24 V
		5 V
Counter[0x].Auto. Advance Sense	Counter function 1 active	TRUE
Counter[0x].Direction	No function	FALSE
Counter[0x].Gray Code	Pulse operation active	FALSE
Counter[0x].Reset	Standard Reset	TRUE
		short-time FALSE

Table 14: Configuration of Counter Function 1

3.4.3.2 Counter Function 2 (Irrespective of the Count Direction Input Signal)

The *Counter[0x].Auto. Advance Sense* set to FALSE, counting with falling edge on input A1 (A2).

The counter increment or decrement is not controlled externally via the input B1 (B2), but by the user program.

Counter[0x].Direction system variable is set to FALSE: counter value increment (higher value),

Counter[0x].Direction system variable is set to TRUE: counter value decrement (lower value).

Input B1 (B2) has no function.

The counter can be reset within the programming tool using the *Counter[0x].Reset* system variable.

Configuration of counter function 2:

System Variable	Description	Value
Counter[0x].5/24V Mode	Inputs	24 V 5 V TRUE FALSE
Counter[0x].Auto. Advance Sense	Counter function 2 active	FALSE
Counter[0x].Direction	Incrementing Decrementing	FALSE TRUE
Counter[0x].Gray Code	Pulse operation active	FALSE
Counter[0x].Reset	Standard Reset	TRUE short-time FALSE

Table 15: Configuration of Counter Function 2

3.4.3.3 Decoder Operation for Gray Code

The 3-bit Gray code of a rotary transducer connected to the inputs A1, B1, Z1 (A2, B2, Z2) is evaluated.

In the user program, use the *Counter[0x].Gray Code* system variable to define this mode of operation individually for each counter.

Configuration of decoder operation:

System Variable	Description	Value
Counter[0x].5/24V Mode	Inputs	24 V 5 V TRUE FALSE
Counter[0x].Auto. Advance Sense	Counter function 1 passive	FALSE
Counter[0x].Direction	No function	FALSE
Counter[0x].Gray Code	Decoder operation active	TRUE
Counter[0x].Reset	Default (no function)	TRUE

Table 16: Configuration of Decoder Operation

3.4.3.4 Comparing the Codes Used

When the counter is operated as a decoder in Gray code, only 1 bit may change when a value on the inputs changes.

3-bit Gray code	Decimal Value	Counter[0x].Value
000	0	0
001	1	1
011	2	3
010	3	2
110	4	6
111	5	7
101	6	5
100	7	4

Table 17: Comparison of the Codes Used

3.4.4 Reset Key

The controller is equipped with a reset key. The key is only required if the user name or password for administrator access is not known. If only the IP address set for the controller does not match the PADT (PC), the connection can be established with a `Route add` entry on the PC.

The key can be accessed through a small round hole located approximately 5 cm from the upper left-hand side of the housing. The key is engaged using a suitable pin made of insulating material to avoid short-circuits within the controller.

The reset is only effective if the controller is rebooted (switched off and on) while the key is simultaneously engaged for at least 20 seconds. Engaging the key during operation has no effect.

WARNING



Caution! Fieldbus communication may be disturbed!

Prior to switching on the controller with the reset key engaged, all device fieldbus connectors must be unplugged to ensure that the fieldbus communication among other stations is not disturbed.

The fieldbus plugs may only be plugged in again when the controller is in the RUN or STOP state.

Properties and behavior of the controller after a reboot with engaged reset key:

- Connection parameters (IP address and system ID) are set to the default values.
- All accounts are deactivated except for the *administrator* default account with empty password.
- Loading a user program or operating system with default connection parameters is inhibited!
The loading procedure is only allowed after the connection parameters and the account have been configured on the controller and the controller has been rebooted.

After a new reboot without the reset key engaged, the connection parameters (IP address and system ID) and accounts become effective.

- Those configured by the user.
- Those valid prior to rebooting with the reset key engaged, if no changes were performed.

3.4.5 Hardware Clock

In case of loss of operating voltage, the power provided by an integrated gold capacitor is sufficient to buffer the hardware clock for approximately one week.

3.5 Product Data

General	
Total program and data memory for all application programs	5 MB less 64 kBytes for CRCs
Response time	≥ 6 ms
Ethernet interfaces	4 x RJ-45, 10/100BaseT (with 100 Mbit/s) with integrated switch
Fieldbus interfaces	3 x 9-pole D-sub FB1 and FB2 with fieldbus submodule pluggable, FB3 with RS485 for Modbus (master or slave) or ComUserTask
Operating Voltage	24 VDC, -15...+20 %, $r_{PP} \leq 15\%$, from a power supply unit with safe insulation in accordance with IEC 61131-2
Current input	max. 9 A (with maximum load) Idle: 0.5 A
Fuse (external)	10 A time-lag (T)
Buffer for date/time	Gold capacitor
Temperature class	T4 (Zone 2)
Operating temperature	0 °C...+60 °C
Storage temperature	-40 °C...+85 °C
Type of protection	IP20
Max. dimensions (without plug)	Width: 257 mm (with housing screws) Height: 114 mm (with fixing bolt) Depth: 97 mm (with earthing screw)
Weight	approx. 1.2 kg

Table 18: Product Data

Digital inputs	
Number of inputs	24 (non-galvanically isolated)
Type of input	Current sinking logic, 24 V, type 1 in accordance with IEC 61131-2
High level: Voltage	freely configurable up to 30 VDC
Current input	approx. 3.5 mA at 24 VDC, approx. 4.5 mA at 30 VDC
Low level: Voltage	freely configurable up to max. high level -2 V safety distance and min. 2 V
Current input	max. 1.5 mA (1 mA at 5 V)
Input resistance	< 7 kΩ
Overvoltage protection	-10 V, +35 V
Max. wire length	300 m
Supply	3 x 20 V / 100 mA, short-circuit-proof
Measurement accuracy at 25 °C, max.	±0.1 % of final value
Metrological accuracy on full temperature, max.	±1 % of final value
Temperature coefficient, max.	±0.023 %/K of final value

Table 19: Specifications for Digital Inputs

Analog Inputs	
Number of inputs	8 (unipolar, non-galvanically isolated)
External shunt adapter for current measurement	Z 7301 (250 Ω) Z 7302 (500 Ω)
Nominal range	0...+10 VDC, 0...+20 mA with 500 Ω shunt
Operating range	-0.1...+11.5 VDC, -0.4...+23 mA with 500 Ω shunt
Input resistance	1 M Ω
Input line	max. 300 m, shielded, twisted pairs of wires
Internal resistance of the signal source	\leq 500 Ω
Digital resolution	12-bit
Measurement accuracy at 25 °C, max.	\pm 0.1 % of final value
Metrological accuracy on full temperature, max.	\pm 0.5 % of final value
Temperature coefficient, max.	\pm 0.011 %/K of full scale
Safety-related accuracy, max.	\pm 2 % of final value
Measured value refresh	once per cycle of the controller
Sampling time	approx. 45 μ s
Transmitter supplies	8 x 24...28 V / \leq 46 mA, short-circuit-proof

Table 20: Specifications for the Analog Inputs

Digital outputs	
Number of outputs	8 (non-galvanically isolated, common ground L-)
Output voltage	L+ minus 2 V
Output current	Channels 1...3 and 5...7: 0.5 A at 60 °C Channels 4 and 8: 1 A at 60 °C (2 A at 50 °C)
Minimum load	2 mA for each channel
Internal voltage drop	max. 2 W at 2 A
Leakage current (with low level)	max. 1 mA at 2 V
Behavior upon overload	The affected output is switched off and cyclically switched on again
Total output current	max. 7 A, upon overload, all outputs are switched off and cyclically switched on again

Table 21: Specifications for the Digital Outputs

Counter	
Number of counters	2 (non-galvanically isolated)
Inputs	3 on each (A, B, Z)
Input voltages High level (5 V) High level (24 V) Low level (5 V) Low level (24 V)	5 V and 24 V 4...6 V 13...33 V 0...0.5 V -3...5 V
Input currents	1.4 mA at 5 V 6.5 mA at 24 V
Input impedance	3.7 kΩ
Input line	max. 500 m, shielded, twisted pairs of wires
Counter resolution	24-bit
Min. pulse length	5 μs
Max. input frequency	100 kHz (at 5 V and 24 V input voltage)
Triggered	on negative edge
Edge steepness	1 V/μs
Pulse duty factor	1 : 1 (for 100 kHz)

Table 22: Specifications for the Counters

3.6 Certified HIMatrix F35

HIMatrix F35	
CE	EMC
TÜV	IEC 61508 1-7:2010 up to SIL 3 IEC 61511:2004 EN ISO 13849-1:2008 IEC 62061:2005 EN 50156-1:2004 EN 298:2003 EN 230:2005
PROFIBUS Nutzerorganisation (PNO)	Test Specification for PROFIBUS DP Slave, Version 3.0 November 2005

Table 23: Certificates

Further safety standards and application standards are specified in the certificate. The certificate and the EC Type-Examination Certificate are available on the HIMA website at www.hima.com.

4 Start-up

To start up the controller, it must be mounted, connected and configured in SILworX.

4.1 Installation and Mounting

The controller is mounted on a 35 mm DIN rail.

4.1.1 Connecting the Digital Inputs

Use the following terminals to connect the digital inputs:

Terminal	Designation	Function
11	LS+	Sensor supply of the inputs 1...8
12	1	Digital input 1
13	2	Digital input 2
14	3	Digital input 3
15	4	Digital input 4
16	5	Digital input 5
17	6	Digital input 6
18	7	Digital input 7
19	8	Digital input 8
20	L-	Ground
Terminal	Designation	Function
21	LS+	Sensor supply of the inputs 9...16
22	9	Digital input 9
23	10	Digital input 10
24	11	Digital input 11
25	12	Digital input 12
26	13	Digital input 13
27	14	Digital input 14
28	15	Digital input 15
29	16	Digital input 16
30	L-	Ground
Terminal	Designation	Function
31	LS+	Sensor supply of the inputs 17...24
32	17	Digital input 17
33	18	Digital input 18
34	19	Digital input 19
35	20	Digital input 20
36	21	Digital input 21
37	22	Digital input 22
38	23	Digital input 23
39	24	Digital input 24
40	L-	Ground

Table 24: Terminal Assignment for the Digital Inputs

4.1.2 Connecting the Digital Outputs

Use the following terminals to connect the digital outputs:

Terminal	Designation	Function
1	L-	Ground channel group
2	1	Digital output 1
3	2	Digital output 2
4	3	Digital output 3
5	4	Digital output 4 (for increased load)
6	5	Digital output 5
7	6	Digital output 6
8	7	Digital output 7
9	8	Digital output 8 (for increased load)
10	L-	Ground channel group

Table 25: Terminal Assignment for the Digital Outputs

4.1.3 Connecting the Counters

In the safety-related application (SIL 3 in accordance with IEC 61508) of the counters, the overall plant including the sensors or encoders connected must comply with the safety requirements. For more information, refer to the HIMatrix Safety Manual (HI 800 023 E).

Only shielded cables with a maximum length of 500 m must be connected to the counter inputs. Each counter input must be connected to a twisted pair of wires. The shielding must be connected at both ends.

All L- connections are interconnected on the controller as a common ground.

The counters are connected to the following terminals:

Terminal	Designation	Function
65	A1	Input A1 or bit 0 (LSB)
66	B1	Input B1 or bit 1
67	Z1	Input Z1 or bit 2 (MSB)
68	L-	Common ground
69	A2	Input A2 or bit 0 (LSB)
70	B2	Input B2 or bit 1
71	Z2	Input Z2 or bit 2 (MSB)
72	L-	Common ground

Table 26: Terminal Assignment for the Counters

Inputs that are not being used need not be terminated.

NOTE



Using the invalid terminal plugs may damage the controller or the sensors or encoders connected to it!

4.1.4 Connecting the Analog Inputs

Use the following terminals to connect the analog inputs:

Terminal	Designation	Function
41	S1S1	Transmitter supply 1
42	I1	Analog input 1
43	I1-	Ground
44	S2	Transmitter supply 2
45	I2	Analog input 2
46	I2-	Ground
Terminal	Designation	Function
47	S3	Transmitter supply 3
48	I3	Analog input 3
49	I3-	Ground
50	S4	Transmitter supply 4
51	I4	Analog input 4
52	I4-	Ground
Terminal	Designation	Function
53	S5	Transmitter supply 5
54	I5	Analog input 5
55	I5-	Ground
56	S6	Transmitter supply 6
57	I6	Analog input 6
58	I6-	Ground
Terminal	Designation	Function
59	S7	Transmitter supply 7
60	I7	Analog input 7
61	I7-	Ground
62	S8	Transmitter supply 8
63	I8	Analog input 8
64	I8-	Ground

Table 27: Terminal Assignment for the Analog Inputs

-
- i** Only shielded cables with a length of a maximum of 300 m must be connected to the analog inputs. Each analog input must be connected to a twisted pair of wires. The shielding must be connected to the controller and the sensor housing and earthed on one end to the controller side to form a Faraday cage.
-

4.1.4.1 Shunt Adapter

The shunt adapter is a plug-in module for the analog inputs of the safety-related HIMatrix F35 controller.

Four variants are available:

Model	Equipment	Part no.
Z 7301	250 Ω shunt	98 2220059
Z 7302	500 Ω shunt	98 2220067
Z 7306	<ul style="list-style-type: none"> ▪ 250 Ω shunt ▪ Overvoltage protection ▪ HART series resistor (current limiting) 	98 2220115
Z 7308	<ul style="list-style-type: none"> ▪ Voltage divider ▪ Overvoltage protection 	98 2220137

Table 28: Shunt Adapter

Refer to the corresponding manuals for further information on the shunt adapters.

4.2 Sequence of Events Recording (SOE)

Global variables of the controller can be monitored using the sequence of events recording. Global variables to be monitored are configured using the programming tool SILworX, see the online help and the SILworX Communication Manual (HI 801 101 E). Up to 4000 events can be configured.

An event is composed of:

Entry data	Description
Event ID	The event ID is assigned by the PADT.
Timestamp	Date (e.g., 21/11/2008-21) Time (e.g., 9:31:57.531)
Event state	Alarm/Normal (boolean event) LL, L, N, H, HH (scalar event)
Event quality	Quality good/ Quality bad, see www.opcfoundation.org

Table 29: Event Description

Events are recorded within the cycle of the user program. The processor system uses global variables to create the events and stores them in its non-volatile event buffer.

The event buffer includes 1000 events. If the event buffer is full, an overflow system event entry is created. Thereafter, events are no longer recorded until existing events have been read and space is once again available in the event buffer.

4.3 Configuring the Controller with SILworX

In the Hardware Editor, the controller is represented like a base plate equipped with the following modules:

- Processor module (CPU)
- Communication module (COM)
- Output module (DO 8)
- Counter module (HSC 2)
- Input module (MI 24/8)

Double-click the module to open the detail view with the corresponding tabs. The tabs of the I/O modules are used to assign the global variables configured in the user program to the system variables of the corresponding module.

4.3.1 Processor Module

The following tables present the parameters for the processor module (CPU) in the same order as given in the Hardware Editor. The Content of the registers Module and Routings of the processor module and the communication module is identical.

4.3.1.1 Tab: **Module**

The **Module** tab contains the following parameters:

Parameter	Description
Name	Module name
Use Max. μ P Budget for HH Protocol	<ul style="list-style-type: none"> ▪ Activated: Use CPU load limit from the <i>Max. μP Budget for HH Protocol [%]</i> field. ▪ Deactivated: Do not use the CPU Load limit for safeethernet. Default setting: Deactivated
Max. μ P Budget for HH Protocol [%]	Maximum CPU load of module that can be used for processing the safe ethernet protocols. <hr/> <p>i The maximum load must be distributed among all the implemented protocols that use this communication module.</p> <hr/>
IP Address	IP address of the Ethernet interface. Default value: 192.168.0.99
Subnet Mask	32 bit address mask to split up the IP address in network and host address. Default value: 255.255.252.0
Standard Interface	Activated: the interface is used as standard interface for the system login. Default setting: Deactivated
Default Gateway	IP address of the default gateway. Default value: 0.0.0.0

Parameter	Description
ARP Aging Time [s]	<p>A processor or COM module stores the MAC addresses of the communication partners in a MAC/IP address assignment table (ARP cache).</p> <p>If in a period of $1x...2x$ <i>ARP Aging Time</i> ...</p> <ul style="list-style-type: none"> - ... messages of the communication are received, the MAC address remains stored in the ARP cache. - ... no messages of the communication partner are received, the MAC address is erased from the ARP cache. <p>The typical value for the <i>ARP Aging Time</i> in a local network ranges from 5...300 s. The user cannot read the contents of the ARP cache.</p> <p>If routers or gateways are used, the user must adjust (increase) the <i>ARP Aging Time</i> due to the additional time required for two-way transmission. If the <i>ARP Aging Time</i> is too low, the processor or the COM module deletes the MAC address of the communication partner from the ARP cache and the communication is either delayed or breaks down entirely. For an efficient performance, the ARP aging time value must be less than the receive timeout set for the protocols in use.</p> <p>Range of values: 1...3600 s Default value: 60 s</p>
MAC Learning	<p>Learning behavior of the ARP cache</p> <ul style="list-style-type: none"> ▪ Conservative: MAC addresses of stored ARP entries are not overwritten by received messages ▪ Tolerant: MAC addresses of stored ARP entries are overwritten by received messages <p>Default setting: Conservative</p>
IP Forwarding	<p>Allow a processor module to operate as router and to forward data packets to other network nodes.</p> <p>Default setting: Deactivated</p>
ICMP Mode	<p>Message types of Internet Control Message Protocol (ICMP) supported by the processor module:</p> <ul style="list-style-type: none"> ▪ No ICMP Responses ▪ Echo Response ▪ Host Unreachable ▪ All Implemented ICMP Responses <p>Default setting: Echo Response</p>

Table 30: Configuration Parameters of the CPU and COM, **Module** Tab

4.3.1.2 Tab: **Routings**

The **Routings** tab contains the following parameters:

Parameter	Description
Name	Denomination of the routing settings
IP Address	Target IP address of the communication partner (with direct host routing) or network address (with subnet routing). Range of values: 0.0.0.0...255.255.255.255 Default value: 0.0.0.0
Subnet Mask	Define the target address range for a routing entry. 255.255.255.255 (with direct host routing) or subnet mask of the addressed subnet. Range of values: 0.0.0.0...255.255.255.255 Default value: 255.255.255.255
Gateway	IP address of the gateway to the addressed network. Range of values: 0.0.0.0...255.255.255.255 Default value: 0.0.0.1

Table 31: Routing Parameters of the CPU and COM

4.3.1.3 Tab: **Ethernet Switch**

The **Ethernet Switch** tab contains the following parameters:

Parameter	Description
Name	Name of the port (Eth1...Eth4) as printed on the housing; per port, only one configuration may exist.
Speed [Mbit/s]	10 Mbit/s: Data rate 10 Mbit/s 100 Mbit/s: Data rate 100 Mbit/s 1000 Mbit/s: Data rate 1000 Mbit/s (not supported) Autoneg: Automatic baud rate setting Default value: Autoneg
Flow Control	Full duplex: Simultaneous communication in both directions Half duplex: Communication in one direction Autoneg: Automatic communication control Default value: Autoneg
Autoneg also with Fixed Values	The <i>Advertising</i> function (forwarding the speed and flow control properties) is also performed if the parameters <i>Speed</i> and <i>Flow Control</i> have fixed values. This allows other devices with ports set to <i>Autoneg</i> to recognize the HiMax port settings. Default setting: Activated
Limit	Limit the inbound multicast and/or broadcast packets. Off: No limitation Broadcast: Limit broadcast packets (128 kbit/s) Multicast and Broadcast: Limit multicast and broadcast packets (1024 kbit/s) Default value: Broadcast

Table 32: Ethernet Switch Parameters

4.3.1.4 Tab: **VLAN** (Port-Based VLAN)

For configuring the use of port-based VLAN.

i

Should VLAN be supported, port-based VLAN should be off to enable each port to communicate with the other switch ports.

For each port on one switch, the user can define which other ports of the switch received Ethernet frames may be sent to.

The table in the VLAN tab contains entries through which the connection between two ports can be set as active or inactive.

	Eth1	Eth2	Eth3	Eth4	COM
Eth1					
Eth2	Active				
Eth3	Active	Active			
Eth4	Active	Active	Active		
COM	Active	Active	Active	Active	
CPU	Active	Active	Active	Active	Active

Table 33: **VLAN** Tab

4.3.1.5 Tab: **LLDP**

With LLDP (Link Layer Discovery Protocol), information such as MAC address, device name, port number is sent per multicast in periodic intervals via the own device and is received from the neighboring devices.

LLDP uses the following values depending on whether PROFINET is configured on the communication module.

PROFINET on the COM module	ChassisID	TTL (Time to Live)
Used	Device name	20 s
Not used	MAC Address	120 s

Table 34: Values for LLDP

The processor and communication modules support LLDP on the Eth1, Eth2, Eth3 and Eth4 ports

The following parameters define how a given port should work:

Off	LLDP is disabled on this port.
Send	LLDP sends LLDP Ethernet frames, received LLDP Ethernet frames are deleted without being processed.
Receive	LLDP sends no LLDP Ethernet frames, but received LLDP Ethernet frames are processed.
Send/Receive	LLDP sends and processes received LLDP Ethernet frames.

Default setting: Send/Receive

4.3.1.6 Tab: **Mirroring**

Mirroring is used to configure whether the module should duplicate Ethernet packets on a given port such that they can be read from a device connected to that port, e.g., for test purposes.

The following parameters define how a given port should work:

Off This port does not participate to the mirroring process.

Egress: Outgoing data of this port are duplicated.

Ingress/Egress: Incoming and outgoing data of this port are duplicated.

Dest Port: This port is used to send duplicated data.

Default setting: OFF

4.3.2 Communication Module

The communication module (COM) contains the **Module** tab and the **Routings** tab. Their content is identical to those of the processor module, see Table 30 and Table 31.

4.3.3 Parameters and Error Codes for the Inputs and Outputs

The following tables specify the system parameters that can be read and set for the inputs and outputs, including the corresponding error codes.

In the user program, the error codes can be read using the variables assigned within the logic.

The error codes can also be displayed in SILworX.

4.3.4 Digital Outputs F35

The following tables present the statuses and parameters for the output module (DO 8) in the same order given in the SILworX Hardware Editor.

4.3.4.1 Tab: **Module**

The **Module** tab contains the following system parameters:

System parameter	Data type	R/W	Description	
DO.Error Code	WORD	R	Error codes for all digital outputs	
			Coding	Description
			0x0001	Fault within the digital outputs
			0x0002	MOT test of safety switch 1 returns a fault
			0x0004	MOT test of safety switch 2 returns a fault
			0x0008	FTT test of test pattern faulty
			0x0010	MOT test of output switch test pattern faulty
			0x0020	MOT test of output switch test pattern (shutdown test of the outputs) faulty
			0x0040	MOT test active shutdown via WD faulty
			0x0200	All outputs are switched off, total current exceeded
			0x0400	FTT test: 1st temperature threshold exceeded
			0x0800	FTT test: 2nd temperature threshold exceeded
0x1000	FTT test: Monitoring of auxiliary voltage 1: Undervoltage			
Module.Error Code	WORD	R	Module error code	
			Coding	Description
			0x0000	I/O processing, if required with errors, see other error codes
			0x0001	No I/O processing (CPU not in RUN)
			0x0002	No I/O processing during the booting test
			0x0004	Manufacturer interface operating
			0x0010	No I/O processing: invalid configuration
			0x0020	No I/O processing: fault rate exceeded
0x0040/ 0x0080	No I/O processing: configured module not plugged in			
Module.SRS	UDINT	R	Slot number (System Rack Slot)	
Module.Type	UINT	R	Type of module, target value: 0x00B4 [180 _{dec}]	

Table 35: System Parameter for Digital Outputs, **Module** Tab

4.3.4.2 Tab: **DO 8: Channels**

The **DO 8: Channels** tab contains the following system parameters.

System parameter	Data type	R/W	Description										
Channel no.	---	R	Channel number, defined by default										
-> Error Code [BYTE]	BYTE	R	Error codes for the digital output channels <table border="1" data-bbox="657 389 1382 607"> <thead> <tr> <th>Coding</th> <th>Description</th> </tr> </thead> <tbody> <tr> <td>0x01</td> <td>Fault in the digital output module</td> </tr> <tr> <td>0x02</td> <td>Channel shutdown due to overload</td> </tr> <tr> <td>0x04</td> <td>Error while reading back the digital outputs</td> </tr> <tr> <td>0x08</td> <td>Error while reading back the status of the digital outputs</td> </tr> </tbody> </table>	Coding	Description	0x01	Fault in the digital output module	0x02	Channel shutdown due to overload	0x04	Error while reading back the digital outputs	0x08	Error while reading back the status of the digital outputs
Coding	Description												
0x01	Fault in the digital output module												
0x02	Channel shutdown due to overload												
0x04	Error while reading back the digital outputs												
0x08	Error while reading back the status of the digital outputs												
Value [BOOL] ->	BOOL	W	Output value for DO channels: 1 = output energized 0 = output de-energized										

Table 36: System Parameters for Digital Outputs, **DO 8: Channels** Tab

4.3.5 Counter F35

The following tables present the statuses and parameters for the counter module (HSC 2) in the same order given in the SILworX Hardware Editor.

4.3.5.1 Tab: **Module**

The **Module** tab contains the following system parameters:

System parameter	Data type	R/W	Description																						
Counter.Error Code	WORD	R	Error code for the counter module																						
			<table border="1"> <thead> <tr> <th>Coding</th> <th>Description</th> </tr> </thead> <tbody> <tr> <td>0x0001</td> <td>Fault within the module</td> </tr> <tr> <td>0x0002</td> <td>Error while comparing the time base</td> </tr> <tr> <td>0x0004</td> <td>Address error while reading the time base</td> </tr> <tr> <td>0x0008</td> <td>Parameters for time base faulty</td> </tr> <tr> <td>0x0010</td> <td>Address error while reading the counter reading</td> </tr> <tr> <td>0x0020</td> <td>Counter configuration corrupted</td> </tr> <tr> <td>0x0040</td> <td>Address error while reading the Gray code</td> </tr> <tr> <td>0x0080</td> <td>FTT test of test pattern faulty</td> </tr> <tr> <td>0x0100</td> <td>FTT test: Fault detected while checking the coefficients</td> </tr> <tr> <td>0x0200</td> <td>Fault during the initial module configuration</td> </tr> </tbody> </table>	Coding	Description	0x0001	Fault within the module	0x0002	Error while comparing the time base	0x0004	Address error while reading the time base	0x0008	Parameters for time base faulty	0x0010	Address error while reading the counter reading	0x0020	Counter configuration corrupted	0x0040	Address error while reading the Gray code	0x0080	FTT test of test pattern faulty	0x0100	FTT test: Fault detected while checking the coefficients	0x0200	Fault during the initial module configuration
			Coding	Description																					
			0x0001	Fault within the module																					
			0x0002	Error while comparing the time base																					
			0x0004	Address error while reading the time base																					
			0x0008	Parameters for time base faulty																					
			0x0010	Address error while reading the counter reading																					
			0x0020	Counter configuration corrupted																					
			0x0040	Address error while reading the Gray code																					
			0x0080	FTT test of test pattern faulty																					
0x0100	FTT test: Fault detected while checking the coefficients																								
0x0200	Fault during the initial module configuration																								
Module.Error Code	WORD	R	Module error code																						
			<table border="1"> <thead> <tr> <th>Coding</th> <th>Description</th> </tr> </thead> <tbody> <tr> <td>0x0000</td> <td>I/O processing, if required with errors, see other error codes</td> </tr> <tr> <td>0x0001</td> <td>No I/O processing (CPU not in RUN)</td> </tr> <tr> <td>0x0002</td> <td>No I/O processing during the booting test</td> </tr> <tr> <td>0x0004</td> <td>Manufacturer interface operating</td> </tr> <tr> <td>0x0010</td> <td>No I/O processing: invalid configuration</td> </tr> <tr> <td>0x0020</td> <td>No I/O processing: fault rate exceeded</td> </tr> <tr> <td>0x0040/ 0x0080</td> <td>No I/O processing: configured module not plugged in</td> </tr> </tbody> </table>	Coding	Description	0x0000	I/O processing, if required with errors, see other error codes	0x0001	No I/O processing (CPU not in RUN)	0x0002	No I/O processing during the booting test	0x0004	Manufacturer interface operating	0x0010	No I/O processing: invalid configuration	0x0020	No I/O processing: fault rate exceeded	0x0040/ 0x0080	No I/O processing: configured module not plugged in						
			Coding	Description																					
			0x0000	I/O processing, if required with errors, see other error codes																					
			0x0001	No I/O processing (CPU not in RUN)																					
			0x0002	No I/O processing during the booting test																					
			0x0004	Manufacturer interface operating																					
			0x0010	No I/O processing: invalid configuration																					
0x0020	No I/O processing: fault rate exceeded																								
0x0040/ 0x0080	No I/O processing: configured module not plugged in																								
Module.SRS	UDINT	R	Slot number (System Rack Slot)																						
Module.Type	UINT	R	Type of module, target value: 0x0003 [3 _{dec}]																						

Table 37: System Parameters for Counters, **Module** Tab

4.3.5.2 Tab: **HSC 2: Channels**

The **HSC 2: Channels** tab contains the following system parameters:

System parameter	Data type	R/W	Description										
Counter[0x].5/24V Mode	BOOL	R/W	5 V or 24 V counter input TRUE: 24 V FALSE: 5 V										
Counter[0x].Auto. Advance Sense	BOOL	R/W	Automatic count direction recognition TRUE: Automatic recognition On FALSE: Manual setting of count direction										
Counter[0x].Direction	BOOL	R/W	Count direction of the counter (only if <i>Counter[0x].Auto. Advance Sense</i> = FALSE) TRUE: Downwards (decrement) FALSE: Upwards (increment)										
Counter[0x].Error Code	BYTE	R	Error codes of counter channels 1 and 2 <table border="1" data-bbox="662 719 1382 936"> <thead> <tr> <th>Coding</th> <th>Description</th> </tr> </thead> <tbody> <tr> <td>0x01</td> <td>Error in counter module</td> </tr> <tr> <td>0x02</td> <td>Error while comparing the counter readings</td> </tr> <tr> <td>0x04</td> <td>Error while comparing the counter timestamp</td> </tr> <tr> <td>0x08</td> <td>Error while setting the parameters (reset)</td> </tr> </tbody> </table>	Coding	Description	0x01	Error in counter module	0x02	Error while comparing the counter readings	0x04	Error while comparing the counter timestamp	0x08	Error while setting the parameters (reset)
Coding	Description												
0x01	Error in counter module												
0x02	Error while comparing the counter readings												
0x04	Error while comparing the counter timestamp												
0x08	Error while setting the parameters (reset)												
Counter[0x].Gray Code	BOOL	R/W	Decoder / pulse operation TRUE: Gray code decoder FALSE: Pulse operation										
Counter[0x].Reset	BOOL	R/W	Counter reset TRUE: No reset FALSE: Reset										
Counter[0x].Spare1... Counter[0x].Spare3	BOOL	R/W	No function										
Counter[0x].Time Overflow	BOOL	R	Overflow indication for the timestamp of the counters TRUE: 24-bit overflow since last measurement FALSE: No 24-bit overflow since last measurement										
Counter[0x].Timestamp	UDINT	R	Timestamp for Counter[0x].Value 24 bits, 1 μ s time resolution										
Counter[0x].Value	UDINT	R	Content of counters: 24 bit for pulse counter, 3 bit for Gray code										
Counter[0x].Value Overflow	BOOL	R	Counter overflow indication TRUE: 24-bit overflow since last cycle (only if <i>Counter[0x].Auto. Advance Sense</i> = FALSE) FALSE: No overflow since last cycle										

Table 38: System Parameters for Counters, **HSC 2: Channels** Tab

4.3.6 Analog and Digital Inputs F35

The following tables present the system parameters for the analog and digital input module (MI 24/8) in the same order given in the SILworX Hardware Editor.

4.3.6.1 Tab: **Module**

The **Module** tab contains the following system parameters:

System parameter	R/W	Description																													
These statuses and parameters are entered directly in the Hardware Editor.																															
FS 1000 / FS 2000	W	Resolution of the -> <i>Value [INT]</i> parameter for the analog input channels. FS 1000: 0...1000 (0...10 V) FS 2000: 0...2000 (0...10 V)																													
System parameter	Data type	R/W	Description																												
AI.Error Code	WORD	R	Error codes for all analog and digital outputs <table border="1" style="width: 100%; border-collapse: collapse;"> <thead> <tr> <th>Coding</th> <th>Description</th> </tr> </thead> <tbody> <tr><td>0x0001</td><td>Module fault</td></tr> <tr><td>0x0004</td><td>MOT test: time monitoring of conversion</td></tr> <tr><td>0x0008</td><td>FTT test: Walking bit of data bus faulty</td></tr> <tr><td>0x0010</td><td>FTT test: Error while checking coefficients</td></tr> <tr><td>0x0020</td><td>FTT test: Operating voltages faulty</td></tr> <tr><td>0x0040</td><td>A/D conversion faulty (DRDY_LOW)</td></tr> <tr><td>0x0080</td><td>MOT test: Cross links of MUX faulty</td></tr> <tr><td>0x0100</td><td>MOT test: Walking bit of data bus faulty</td></tr> <tr><td>0x0200</td><td>MOT test: Multiplexer addresses faulty</td></tr> <tr><td>0x0400</td><td>MOT test: Operating voltages faulty</td></tr> <tr><td>0x0800</td><td>MOT test: Measuring system (characteristic) faulty (unipolar)</td></tr> <tr><td>0x1000</td><td>MOT test: Measuring system (final values, zero point) faulty (unipolar)</td></tr> <tr><td>0x8000</td><td>A/D conversion faulty (DRDY_HIGH)</td></tr> </tbody> </table>	Coding	Description	0x0001	Module fault	0x0004	MOT test: time monitoring of conversion	0x0008	FTT test: Walking bit of data bus faulty	0x0010	FTT test: Error while checking coefficients	0x0020	FTT test: Operating voltages faulty	0x0040	A/D conversion faulty (DRDY_LOW)	0x0080	MOT test: Cross links of MUX faulty	0x0100	MOT test: Walking bit of data bus faulty	0x0200	MOT test: Multiplexer addresses faulty	0x0400	MOT test: Operating voltages faulty	0x0800	MOT test: Measuring system (characteristic) faulty (unipolar)	0x1000	MOT test: Measuring system (final values, zero point) faulty (unipolar)	0x8000	A/D conversion faulty (DRDY_HIGH)
Coding	Description																														
0x0001	Module fault																														
0x0004	MOT test: time monitoring of conversion																														
0x0008	FTT test: Walking bit of data bus faulty																														
0x0010	FTT test: Error while checking coefficients																														
0x0020	FTT test: Operating voltages faulty																														
0x0040	A/D conversion faulty (DRDY_LOW)																														
0x0080	MOT test: Cross links of MUX faulty																														
0x0100	MOT test: Walking bit of data bus faulty																														
0x0200	MOT test: Multiplexer addresses faulty																														
0x0400	MOT test: Operating voltages faulty																														
0x0800	MOT test: Measuring system (characteristic) faulty (unipolar)																														
0x1000	MOT test: Measuring system (final values, zero point) faulty (unipolar)																														
0x8000	A/D conversion faulty (DRDY_HIGH)																														
Module.Error Code	WORD	R	Module error code <table border="1" style="width: 100%; border-collapse: collapse;"> <thead> <tr> <th>Coding</th> <th>Description</th> </tr> </thead> <tbody> <tr><td>0x0000</td><td>I/O processing, if required with errors, see other error codes</td></tr> <tr><td>0x0001</td><td>No I/O processing (CPU not in RUN)</td></tr> <tr><td>0x0002</td><td>No I/O processing during the booting test</td></tr> <tr><td>0x0004</td><td>Manufacturer interface operating</td></tr> <tr><td>0x0010</td><td>No I/O processing: invalid configuration</td></tr> <tr><td>0x0020</td><td>No I/O processing: fault rate exceeded</td></tr> <tr><td>0x0040/ 0x0080</td><td>No I/O processing: configured module not plugged in</td></tr> </tbody> </table>	Coding	Description	0x0000	I/O processing, if required with errors, see other error codes	0x0001	No I/O processing (CPU not in RUN)	0x0002	No I/O processing during the booting test	0x0004	Manufacturer interface operating	0x0010	No I/O processing: invalid configuration	0x0020	No I/O processing: fault rate exceeded	0x0040/ 0x0080	No I/O processing: configured module not plugged in												
Coding	Description																														
0x0000	I/O processing, if required with errors, see other error codes																														
0x0001	No I/O processing (CPU not in RUN)																														
0x0002	No I/O processing during the booting test																														
0x0004	Manufacturer interface operating																														
0x0010	No I/O processing: invalid configuration																														
0x0020	No I/O processing: fault rate exceeded																														
0x0040/ 0x0080	No I/O processing: configured module not plugged in																														
Module.SRS	UDINT	R	Slot number (System Rack Slot)																												
Module.Type	UINT	R	Type of module, target value: 0x00D2 [210 _{dec}]																												

Table 39: System Parameter for Inputs, **Module** Tab

4.3.6.2 Tab: MI 24/8: AI-Channels

The **MI 24/8: AI-Channels** tab contains the following system parameters.

System parameter	Data type	R/W	Description																		
Channel no.	---	R	Channel number, defined by default																		
-> Error Code [BYTE]	BYTE	R	Error codes for the analog input channels (1...8) <table border="1" data-bbox="667 421 1385 817"> <thead> <tr> <th>Coding</th> <th>Description</th> </tr> </thead> <tbody> <tr> <td>0x01</td> <td>Fault in the analog input module</td> </tr> <tr> <td>0x02</td> <td>Not used</td> </tr> <tr> <td>0x04</td> <td>A/D converter faulty, measured values invalid</td> </tr> <tr> <td>0x08</td> <td>Measured value out of the safety-related accuracy</td> </tr> <tr> <td>0x10</td> <td>Measured value overflow</td> </tr> <tr> <td>0x20</td> <td>Channel not operating</td> </tr> <tr> <td>0x40</td> <td>Address error of both A/D converters</td> </tr> <tr> <td>0x80</td> <td>Configuration of the hysteresis faulty</td> </tr> </tbody> </table>	Coding	Description	0x01	Fault in the analog input module	0x02	Not used	0x04	A/D converter faulty, measured values invalid	0x08	Measured value out of the safety-related accuracy	0x10	Measured value overflow	0x20	Channel not operating	0x40	Address error of both A/D converters	0x80	Configuration of the hysteresis faulty
Coding	Description																				
0x01	Fault in the analog input module																				
0x02	Not used																				
0x04	A/D converter faulty, measured values invalid																				
0x08	Measured value out of the safety-related accuracy																				
0x10	Measured value overflow																				
0x20	Channel not operating																				
0x40	Address error of both A/D converters																				
0x80	Configuration of the hysteresis faulty																				
-> Value [INT]	INT	R	Analog value of the AI channels (1...8) [INT] from 0...1000 (variant: FS 1000), 0...2000 (variant: FS 2000) (0 V...+10 V) The validity depends on the <i>AI.Error Code</i> .																		
Channel Used [BOOL] ->	BOOL	W	Configuration of the channels 1...8: 1 = Channel operating 0 = Channel not operating																		

Table 40: System Parameter for Inputs, **MI 24/8: AI Channels** Tab

4.3.6.3 Tab: **MI 24/8: DI-Channels**

The **MI 24/8: DI-Channels** tab contains the following system parameters.

System parameter	Data type	R/W	Description																		
Channel no.	---	R	Channel number, defined by default																		
-> Error Code [BYTE]	BYTE	R	Error codes for the digital input channels (1...24). <table border="1" data-bbox="715 421 1433 817"> <thead> <tr> <th>Coding</th> <th>Description</th> </tr> </thead> <tbody> <tr> <td>0x01</td> <td>Fault in the analog input module</td> </tr> <tr> <td>0x02</td> <td>Not used</td> </tr> <tr> <td>0x04</td> <td>A/D converter faulty, measured values invalid</td> </tr> <tr> <td>0x08</td> <td>Measured value out of the safety-related accuracy</td> </tr> <tr> <td>0x10</td> <td>Measured value overflow</td> </tr> <tr> <td>0x20</td> <td>Channel not operating</td> </tr> <tr> <td>0x40</td> <td>Address error of both A/D converters</td> </tr> <tr> <td>0x80</td> <td>Configuration of the hysteresis faulty</td> </tr> </tbody> </table>	Coding	Description	0x01	Fault in the analog input module	0x02	Not used	0x04	A/D converter faulty, measured values invalid	0x08	Measured value out of the safety-related accuracy	0x10	Measured value overflow	0x20	Channel not operating	0x40	Address error of both A/D converters	0x80	Configuration of the hysteresis faulty
Coding	Description																				
0x01	Fault in the analog input module																				
0x02	Not used																				
0x04	A/D converter faulty, measured values invalid																				
0x08	Measured value out of the safety-related accuracy																				
0x10	Measured value overflow																				
0x20	Channel not operating																				
0x40	Address error of both A/D converters																				
0x80	Configuration of the hysteresis faulty																				
-> Value [BOOL]	BOOL	R	Analog value of the DI channels (1...24) [BOOL] in accordance with the hysteresis. The validity depends on -> <i>Error Code [BYTE]</i> .																		
-> Value - analog [INT]	INT	R	Analog value of the DI channels (1...24) [INT] from 0...3000 (0...30 V). The validity depends on -> <i>Error Code [BYTE]</i> .																		
Channel Used [BOOL] ->	BOOL	W	Configuration of channels 1...24: 1 = Channel operating 0 = Channel not operating																		
Hysteresis LOW [INT] ->	INT	W	Upper limit of the low level voltage range -> <i>Value [BOOL]</i>																		
Hysteresis HIGH [INT] ->	INT	W	Lower limit of the high level voltage range -> <i>Value [BOOL]</i>																		

Table 41: System Parameter for Inputs, **MI 24/8: DI Channels** Tab

4.4 Connection Variants

This chapter describes the permissible wiring of the controller in safety-related applications. Only the connection variants specified here are permitted for SIL 3 applications.

4.4.1 Wired Mechanical Contacts on Analog Inputs

Wired mechanical contacts are connected to the analog inputs using the Z 7308 shunt adapter, see Figure 8. The shunt adapter protects the analog inputs against overvoltage and short-circuits from the field zone.

Each analog input has a supply output that is fed by a common AI power source. The supply voltage is between 26.7 V and 27.3 V.

The supply of the analog inputs must be monitored. To do so, the used supply outputs (S1...S8) must be connected in parallel and attached to a digital input. The evaluation of the digital input is analog and must be configured in the programming tool accordingly.

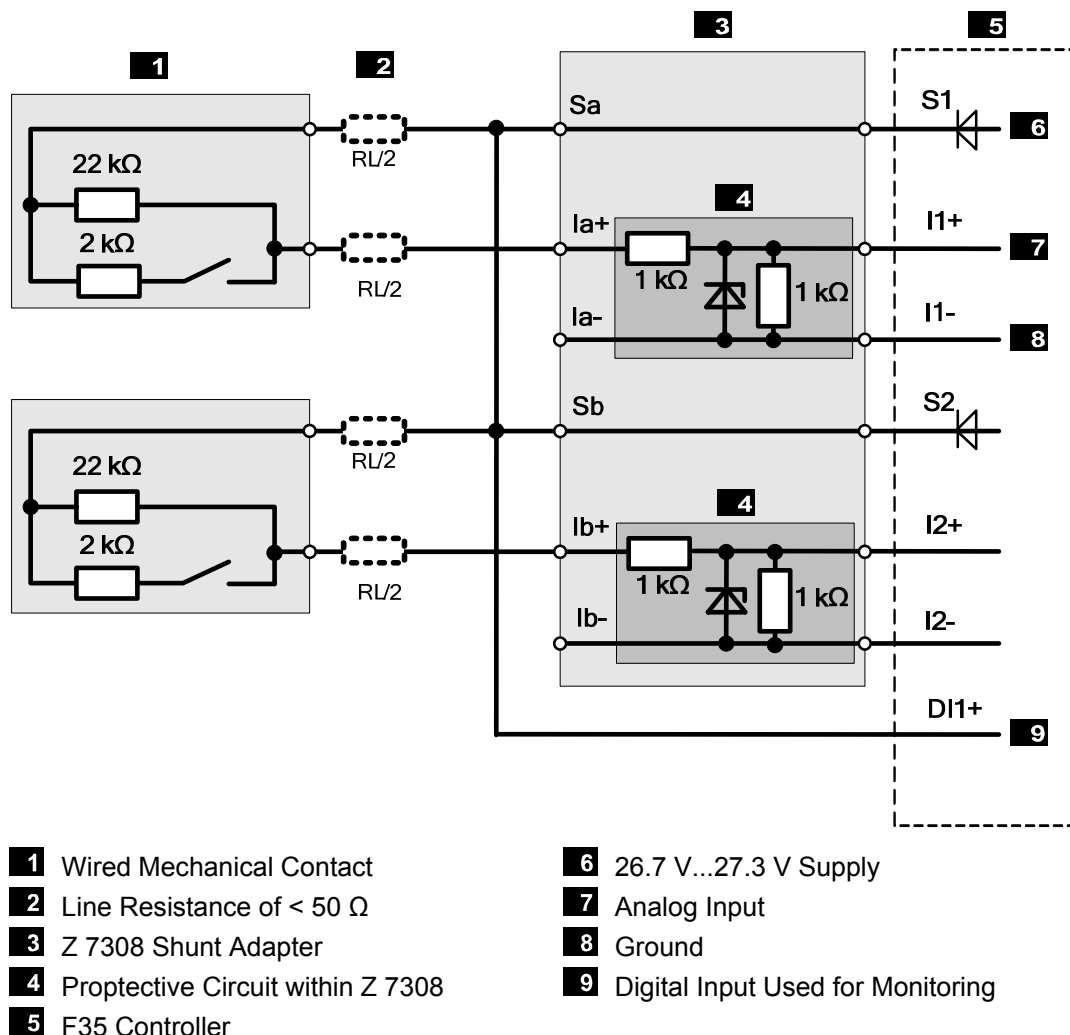

Figure 8: Wired Mechanical Contact on Analog Inputs

4.4.1.1 Switching Thresholds of the Analog Inputs for Mechanical Contacts

For FS 2000 resolution, the switch-on and switch-off thresholds, the open-circuit (OC) and short-circuit (SC) thresholds and the corresponding fault reaction must be configured in the user program.

The values specified in the following table apply for wired mechanical contacts with resistance values of 2 k Ω und 22 k Ω .

Switching thresholds	Range of 2000 digits	Description
Switch-on threshold L \rightarrow H	6 V [1200 digits]	Transition from Low to High
Switch-off threshold H \rightarrow L	3 V [600 digits]	Transition from High to Low
OC threshold	\leq 0.5 V [100 digits]	Fault reaction to be configured: Set the input value to faulty.
SC threshold	\geq 8.4 V [1680 digits]	Fault reaction to be configured: Set the input value to faulty.

Table 42: Thresholds for the Analog Inputs

4.4.1.2 Switching Thresholds Used for Monitoring the Supply

For monitoring the supply of the analog inputs must be read back by a digital input. To do so, the following values must be entered in the system parameters for the digital input.

System parameter	Value
Hysteresis LOW [INT] ->	< 26 V [2600 digits]
Hysteresis HIGH [INT] ->	> 28 V [2800 digits]

Table 43: Switching Thresholds for the Digital Inputs Used for Monitoring the Supply

If the supply voltage is outside the limits defined with the system parameters *Hysteresis LOW [INT] ->* and *Hysteresis HIGH [INT] ->*, the value of the measuring inputs must be set to faulty. The values of the mechanical contacts must not be evaluated in the user program.

If the supply voltage is once again within the defined range limits, operations can be resumed.

4.4.2 Wired Mechanical Contacts on Digital Inputs

Wired mechanical contacts are connected as described in Figure 9 and Figure 10.

Each of the 3 supply outputs supplies a group of 8 digital inputs. The supply voltage lies between 16.7 V and 26.9 V.

The 3 supply outputs must be monitored. To do so, each of the used supply outputs must be connectet with a digital input. The evaluation of the digital input is analog and must be configured in the programming tool accordingly.

4.4.2.1 Wired Mechanical Contacts With Resistance Values of 2 kΩ and 22 kΩ

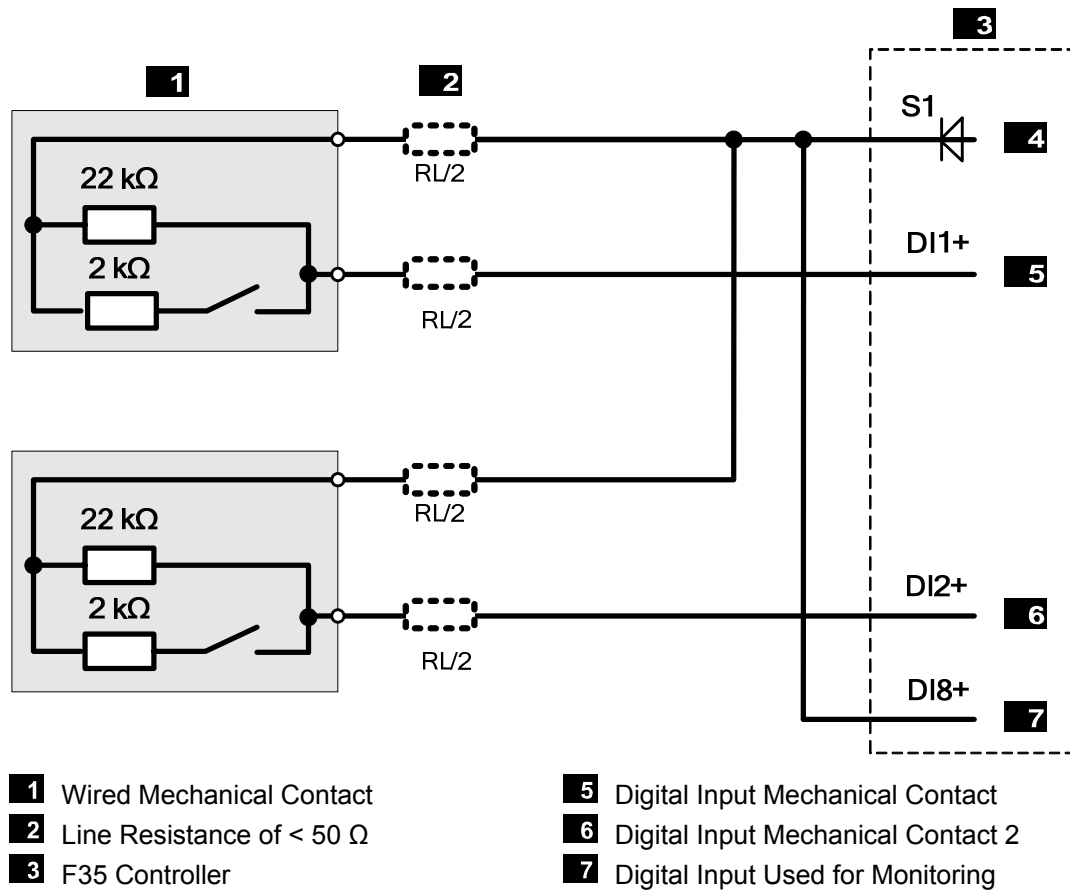

Figure 9: Wired Mechanical Contact on Digital Inputs

Switching Thresholds for the Digital Inputs

The switch-on and switch-off thresholds, the open-circuit (OC) and short-circuit (SC) thresholds and the corresponding fault reaction must be configured in the user program. The SC threshold must be determined in the user program by reading back the voltage supply. The SC threshold is equal to the measured supply value minus 1.1 V.

The values specified in the following table apply for wired mechanical contacts with resistance values of 2 kΩ und 22 kΩ:

Switching thresholds	Value	Description
Switch-on threshold L → H	> 12 V [1200 digits]	Transition from Low to High
Switch-off threshold H → L	< 10 V [1000 digits]	Transition from High to Low
OC threshold	< 2 V [200 digits]	Fault reaction to be configured: Set the input value to zero.
SC threshold	Supply - 1.1 V [110 digits]	Fault reaction to be configured: Set the input value to zero.

Table 44: Switching Thresholds for the Digital Inputs for Wired Mechanical Contacts with Resistance Values of 2 kΩ and 22 kΩ

4.4.2.2 Wired Mechanical Contacts with Resistance Values of 2.1 kΩ and 22 kΩ

A BARTEC resistive coupling element (HIMA part no. 88 0007829) is connected upstream to the contact maker, see Figure 10.

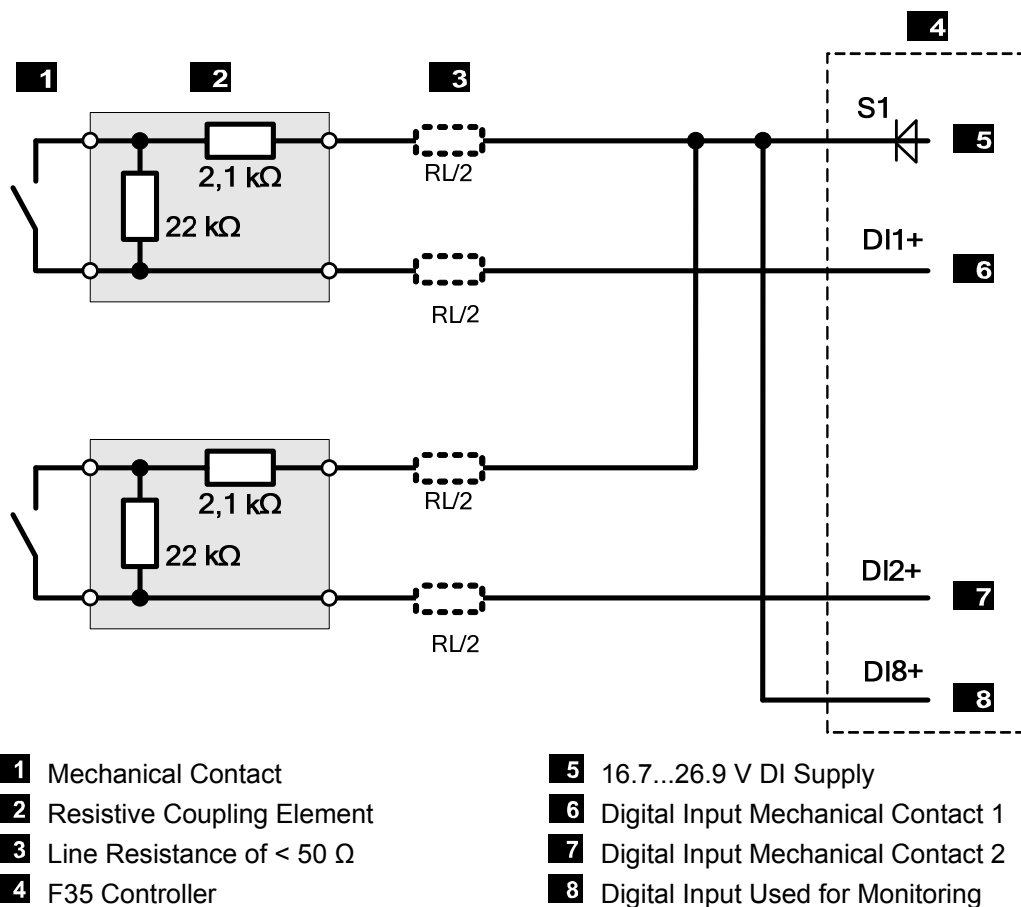

Figure 10: Mechanical Contact with Resistive Coupling Element

Switching Thresholds for the Digital Inputs

The switch-on and switch-off thresholds, the open-circuit (OC) and short-circuit (SC) thresholds and the corresponding fault reaction must be configured in the user program. The SC threshold must be determined in the user program by reading back the voltage supply. The SC threshold is equal to the measured supply value minus 1.1 V.

The value for the switching thresholds specified in Table 45 apply for wired mechanical contacts with resistance values of 2.1 k Ω and 22 k Ω , see Figure 10.

Switching threshold	Value	Description
Switch-on threshold L \rightarrow H	> 11.5 V [1150 digits]	Transition from Low to High
Switch-off threshold H \rightarrow L	< 9.5 V [950 digits]	Transition from High to Low
OC threshold	< 2 V [200 digits]	Fault reaction to be configured: Set the input value to zero.
SC threshold	Supply - 1.1 V [110 digits]	Fault reaction to be configured: Set the input value to zero.

Table 45: Switching Thresholds for the Digital Inputs for Mechanical Contacts with Resistive Coupling Element

5 Operation

The controller F35 is ready for operation. No specific monitoring is required for the controller.

5.1 Handling

Handling of the controller during operation is not required.

5.2 Diagnosis

A first diagnosis results from evaluating the LEDs, see Chapter 3.4.1.

The device diagnostic history can also be read using the programming tool SILworX.

6 Maintenance

No maintenance measures are required during normal operation.

If a device or module fails, it must be replaced with a faultless device or module of the same type or with an approved replacement model.

Only the manufacturer is authorized to repair the device/module.

6.1 Faults

Refer to Chapter 3.1.1.1, for more information on the fault reaction of digital inputs.

Refer to Chapter 3.1.2.1, for more information on the fault reaction of digital outputs.

Refer to Chapter 3.1.3.1, for more information on the fault reaction of counters.

Refer to Chapter 3.1.4.2, for more information on the fault reaction of analog inputs.

If the test harnesses detect faults in the processor system, the device is rebooted. If a further internal fault occurs within the first minute after start-up, the device enters the STOP_INVALID state and will remain in this state. This means that the input signals are no longer processed by the device and the outputs switch to the de-energized, safe state. The evaluation of diagnostics provides information on the fault cause.

6.2 Maintenance Measures

The following measures are required for the processor module:

- Loading the operating system, if a new version is required
- Executing the proof test

6.2.1 Loading the Operating System

HIMA is continuously improving the operating system of the devices. HIMA recommends to use system downtimes to load a current version of the operating system into the devices.

Refer to the release list to check the consequences of the new operation system version on the system!

Load the operating system using the programming tool.

Prior to loading the operating system, the device must be in STOP (displayed in the programming tool). Otherwise, stop the device.

For more information, refer to the programming tool documentation.

6.2.2 Proof Test

Test the HIMatrix devices and modules every 10 years. For more information, refer to the Safety Manual (HI 800 003 E).

7 Decommissioning

Remove the supply voltage to decommission the device. Afterwards pull out the pluggable screw terminal connector blocks for inputs and outputs and the Ethernet cables.

8 Transport

To avoid mechanical damage, HIMatrix components must be transported in packaging.

Always store HIMatrix components in their original product packaging. This packaging also provides protection against electrostatic discharge. Note that the product packaging alone is not suitable for transmission.

9 Disposal

Industrial customers are responsible for correctly disposing of decommissioned HIMatrix hardware. Upon request, a disposal agreement can be arranged with HIMA.

All materials must be disposed of in an ecologically sound manner.

Appendix

Glossary

Term	Description
ARP	Address Resolution Protocol: Network protocol for assigning the network addresses to hardware addresses
AI	Analog Input
COM	COMmunication module
CRC	Cyclic Redundancy Check
DI	Digital Input
DO	Digital Output
EMC	ElectroMagnetic Compatibility
EN	European Norm
ESD	ElectroStatic Discharge
FB	FieldBus
FBD	Function Block Diagrams
FTA	Field Termination Assembly
FTT	Fault Tolerance Time
ICMP	Internet Control Message Protocol: Network protocol for status or error messages
IEC	International Electrotechnical Commission
MAC Address	Media Access Control address: Hardware address of one network connection
PADT	Programming And Debugging Tool (in accordance with IEC 61131-3), PC with SILworX
PE	Protective Earth
PELV	Protective Extra Low Voltage
PES	Programmable Electronic System
PFD	Probability of Failure on Demand, probability of failure on demand of a safety function
PFH	Probability of Failure per Hour, probability of a dangerous failure per hour
R	Read: The system variable or signal provides value, e.g., to the user program
Rack ID	Base plate identification (number)
Non-reactive	Supposing that two input circuits are connected to the same source (e.g., a transmitter). An input circuit is termed <i>non-reactive</i> if it does not distort the signals of the other input circuit.
R/W	Read/Write (column title for system variable/signal type)
SB	System Bus (module)
SELV	Safety Extra Low Voltage
SFF	Safe Failure Fraction, portion of safely manageable faults
SIL	Safety Integrity Level (in accordance with IEC 61508)
SILworX	Programming tool for HIMatrix systems
SNTP	Simple Network Time Protocol (RFC 1769)
S.R.S	System.Rack.Slot addressing of a module
SW	Software
TMO	TiMeOut
W	Write: System variable/signal is provided with value, e.g., from the user program
WD	WatchDog: Time monitoring for modules or programs. If the watchdog time is exceeded, the module or program enters the ERROR STOP state.
WDT	Watchdog Time

Index of Figures

Figure 1: Connections to Safety-Related Digital Inputs	13
Figure 2: Connection of Actuators to Outputs	14
Figure 3: Circuitry for Line Monitoring	17
Figure 4: Sample Type Label	19
Figure 5: Front View	20
Figure 6: Block Diagram	20
Figure 7: Sample MAC Address Label	24
Figure 8: Wired Mechanical Contact on Analog Inputs	48
Figure 9: Wired Mechanical Contact on Digital Inputs	50
Figure 10: Mechanical Contact with Resistive Coupling Element	51

Index of Tables

Table 1: Additional Relevant Documents	7
Table 2: Environmental Requirements	10
Table 3: Input Values for the Analog Inputs	16
Table 4: Values for Circuitry for Line Monitoring	17
Table 5: Part Numbers	19
Table 6: Blinking Frequencies of LEDs	21
Table 7: Operating Voltage LED	21
Table 8: System LEDs	22
Table 9: Ethernet Indicators	23
Table 10: I/O LEDs	23
Table 11: Ethernet Interfaces Properties	24
Table 12: Network Ports (UDP Ports) in Use	25
Table 13: Network Ports (TCP Ports) in Use	25
Table 14: Configuration of Counter Function 1	26
Table 15: Configuration of Counter Function 2	27
Table 16: Configuration of Decoder Operation	27
Table 17: Comparison of the Codes Used	27
Table 18: Product Data	29
Table 19: Specifications for Digital Inputs	29
Table 20: Specifications for the Analog Inputs	30
Table 21: Specifications for the Digital Outputs	30
Table 22: Specifications for the Counters	31
Table 23: Certificates	31
Table 24: Terminal Assignment for the Digital Inputs	32
Table 25: Terminal Assignment for the Digital Outputs	33
Table 26: Terminal Assignment for the Counters	33

Table 27:	Terminal Assignment for the Analog Inputs	34
Table 28:	Shunt Adapter	35
Table 29:	Event Description	35
Table 30:	Configuration Parameters of the CPU and COM, Module Tab	37
Table 31:	Routing Parameters of the CPU and COM	38
Table 32:	Ethernet Switch Parameters	38
Table 33:	VLAN Tab	39
Table 34:	Values for LLDP	39
Table 35:	System Parameter for Digital Outputs, Module Tab	41
Table 36:	System Parameters for Digital Outputs, DO 8: Channels Tab	42
Table 37:	System Parameters for Counters, Module Tab	43
Table 38:	System Parameters for Counters, HSC 2: Channels Tab	44
Table 39:	System Parameter for Inputs, Module Tab	45
Table 40:	System Parameter for Inputs, MI 24/8: AI Channels Tab	46
Table 41:	System Parameter for Inputs, MI 24/8: DI Channels Tab	47
Table 42:	Thresholds for the Analog Inputs	49
Table 43:	Switching Thresholds for the Digital Inputs Used for Monitoring the Supply	49
Table 44:	Switching Thresholds for the Digital Inputs for Wired Mechanical Contacts with Resistance Values of 2 kΩ and 22 kΩ	51
Table 45:	Switching Thresholds for the Digital Inputs for Mechanical Contacts with Resistive Coupling Element	52

Index

diagnosis.....	53	line monitoring	17
fault reaction		part number	19
analog Inputs.....	18	reset key	28
counter inputs.....	15	safeethernet.....	24
digital inputs	13	shunt adapter.....	35
digital outputs	14	specifications	29
line control.....	13	SRS	19



SAFETY
NONSTOP

HIMA Paul Hildebrandt GmbH + Co KG

P.O. Box 1261

68777 Brühl, Germany

Phone: +49 6202 709-0

Fax: +49 6202 709-107

E-mail: info@hima.com Internet: www.hima.com

(1124)