

CLASS 6 D-STYLE SMARTMOTOR™

High Power in a Small Package

Fully integrated controller with small footprint, great power density and a simplicity of design hard to match on the market.



The drive to improve the performance of its SmartMotor™, while minimizing footprint, sets Moog Animatics apart from its competitors, reinforcing its position as the industry leading provider of fully integrated motors with motion control capabilities.

The Class 6 D-Style SmartMotor™ offer an extended power range (up to 1 kW) in the same compact package of previous series, provides improved torque density and increased performance without affecting the overall design of the machine.

These enhanced capabilities are combined with industrial Ethernet connectivity and a multi-turn absolute encoder enabling extreme design flexibility for any application.

Features:

- Absolute multi-turn battery-less encoder with 22-bit multi-turn and 17-bit single-turn resolution
- Wider ambient operating temperature range (-20° to 100° C)
- Industry standard 24 VDC I/O
- Separate 24 V Supply for Logic backup
- Communications via RS-232 and CAN over the 7W2 power connector enabling single cable control
- NEMA 17, 23 and 34 frame sizes
- Inline brake options for all models
- Optional Industrial Ethernet fieldbuses (EtherCAT®, EtherNet/IP™, PROFINET®)
- Easy connection to diagnostics over USB

ADVANTAGES

- Fully integrated, compact motion system
- High noise immunity
- Industry leading power density
- High tuning bandwidth
- Enhanced controls with ability to handle complex applications

APPLICATIONS

- Automated Guided Vehiles (AGVs)
- Factory automation
- Medical
- Packaging
- Pan and tilt applications
- Semiconductor wafer handling
- Test and measurement



SPECIFICATIONS

TECHNICAL DATA

Model	Frame Size	Continuous Torque	Peak Torque	Nominal Power	No Load Speed
 SM17166D*	NEMA 17	TBA	TBA	TBA	TBA
 SM23166D	NEMA 23	0.31 Nm [44 oz-in]	0.57 Nm [81 oz-in]	170 watts	9000 rpm
 SM23166DT	NEMA 23	0.64 Nm [91 oz-in]	1.06 Nm [151 oz-in]	195 watts	4800 rpm
 SM23376DT	NEMA 23	0.69 Nm [98 oz-in]	1.6 Nm [227 oz-in]	193 watts	4132 rpm
 SM23266DT	NEMA 23	0.67 Nm [95 oz-in]	1.24 Nm [176 oz-in]	260 watts	6400 rpm
 SM34166DT shown with brake*	NEMA 34	TBA	TBA	TBA	TBA
 SM34266DT*	NEMA 34	TBA	TBA	TBA	TBA

*NEMA Frame Sizes 17 and 34 models will be available soon, contact factory for more information.

SPECIFICATIONS

SPECIFICATIONS

Dimension	Unit	SM23166D 24 V/48 V	SM23166DT 24 V/48 V	SM23376DT 24 V/48 V	SM23266DT 24 V/48 V
Continuous torque	in-lb	2.75	5.68	5.59/6.10	6.15/5.91
	oz-in	44	91	89/98	98/95
	N-m	0.31	0.64	0.63/0.69	0.70/0.67
Peak torque	in-lb	5.06	9.43	12.52/14.16	10.99
	oz-in	81	151	200/227	176
	N-m	0.57	1.06	1.41/1.60	1.24
Nominal continuous power	watts	70/170	83/195	77/193	150/260
No load speed	rpm	4,500/9,000	2,400/4,800	1998/4132	3250/6400
Max. continuous current* @ 1,600 RPM	amps	7/6	7	7	11/9
Max. peak current	amps	13/9	17/10	15/14	17/12
Single turn encoder resolution (maximum) 17-bit	count/rev	131,072	131,072	131,072	131,072
Single turn encoder resolution to user (maximum) 14-bit	count/rev	16,384	16,384	16,384	16,384
Accuracy	degrees	±0.1	±0.1	±0.1	±0.1

OPTIONS INFORMATION

Available options for all models:

- Brake
- CANopen - standard
- MODBUS RTU - standard
- MODBUS TCP - standard with EtherNet/IP™
- EtherNet/IP™
- PROFINET®
- EtherCAT®

SPECIFICATIONS

OUTLINE DRAWINGS

SM23166D

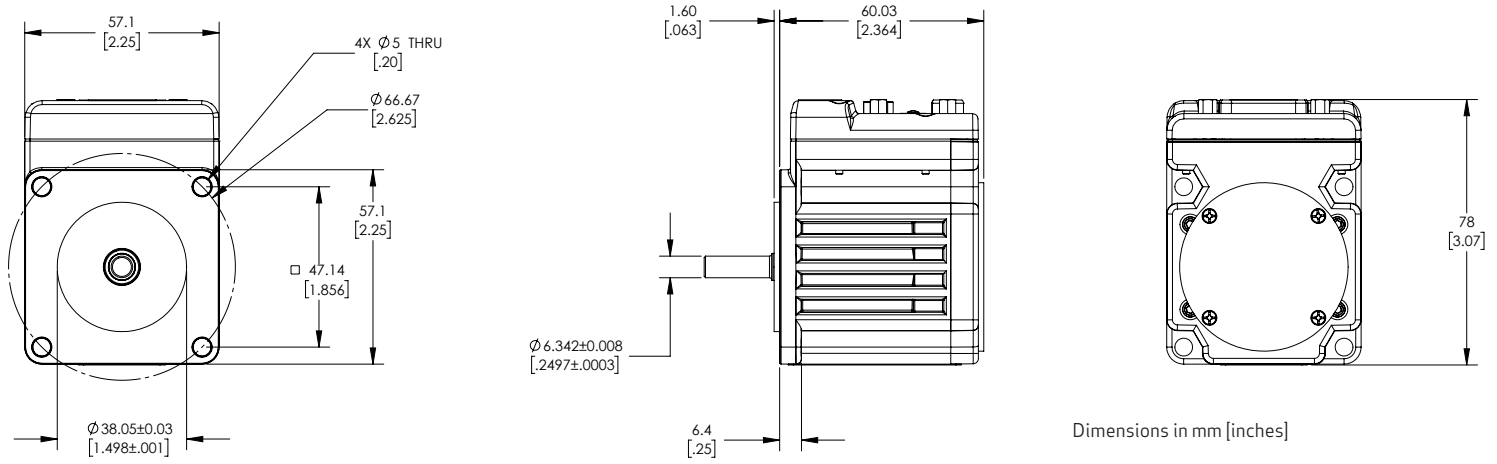

SM23166D w/Brake

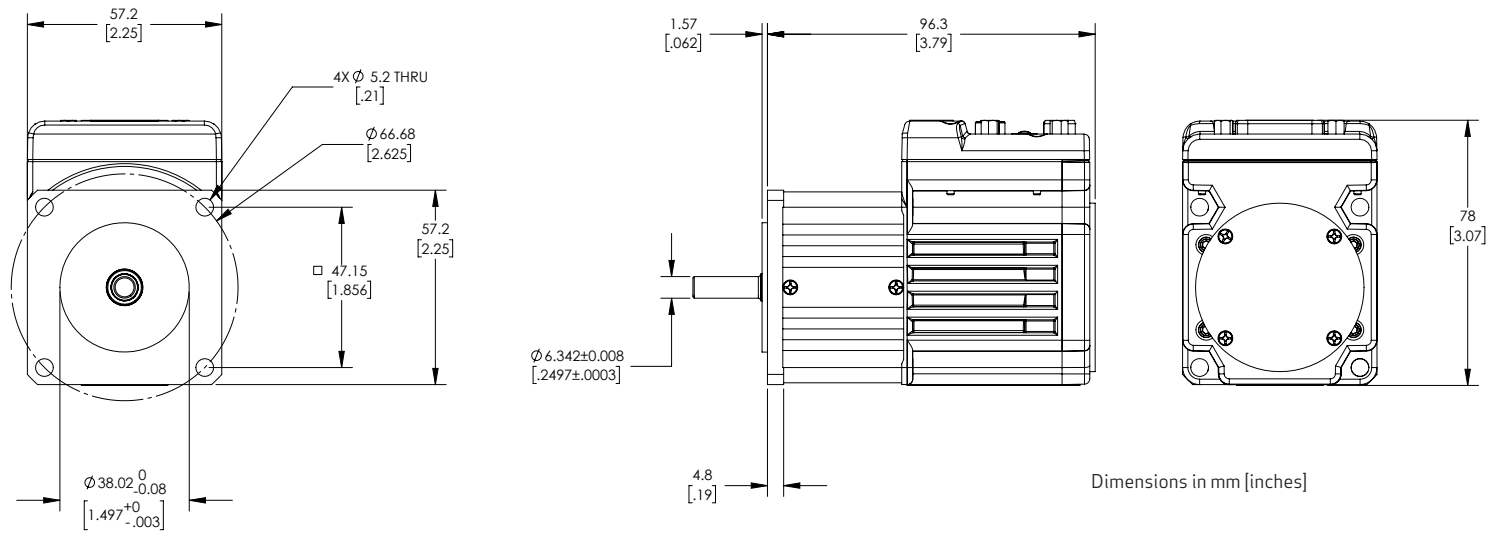

SM23166DT

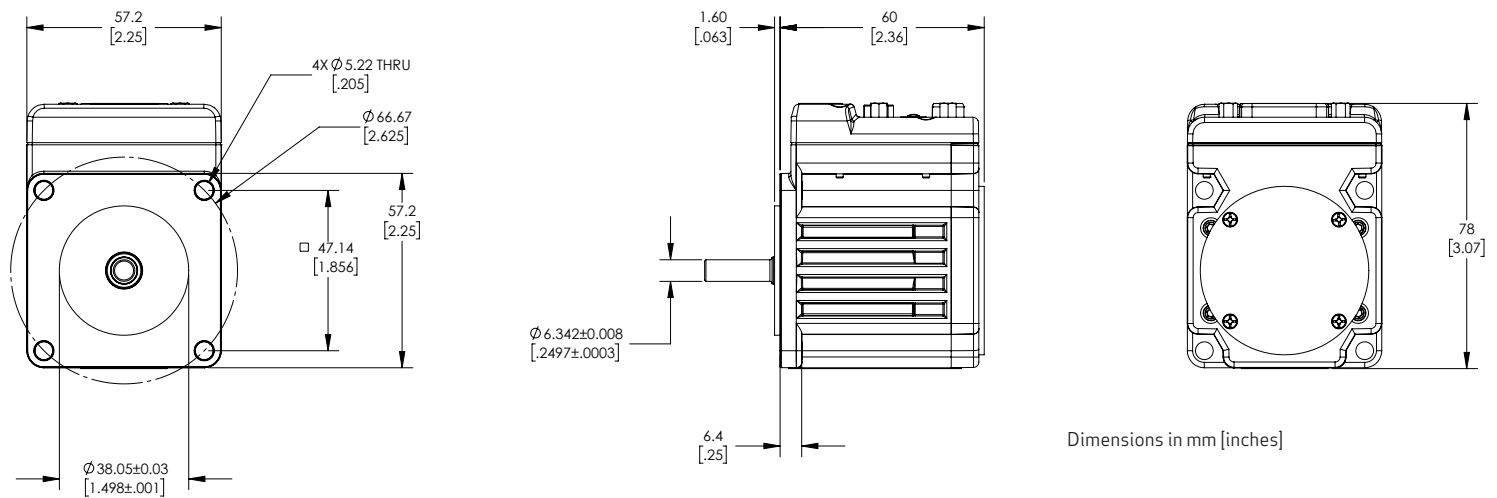

NOTE: Motor specifications are subject to changes without notice. Consult website and factory for latest data.

SPECIFICATIONS

OUTLINE DRAWINGS

SM23166DT w/Brake

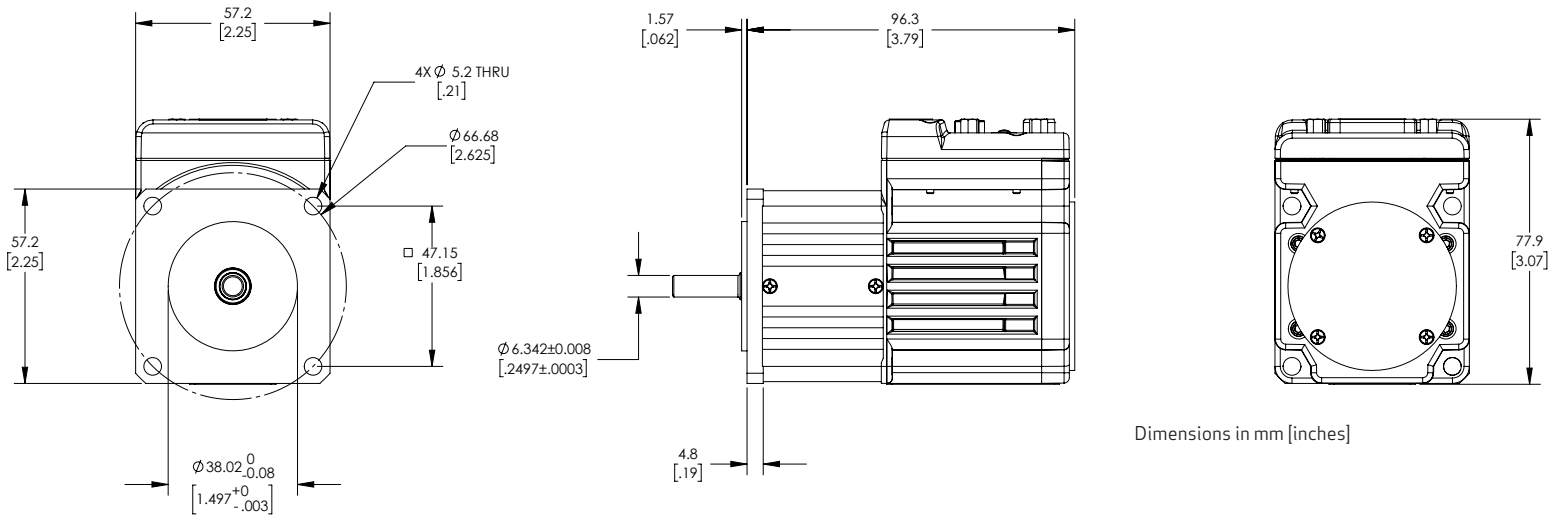

SM23376DT/SM23376DT w/Brake

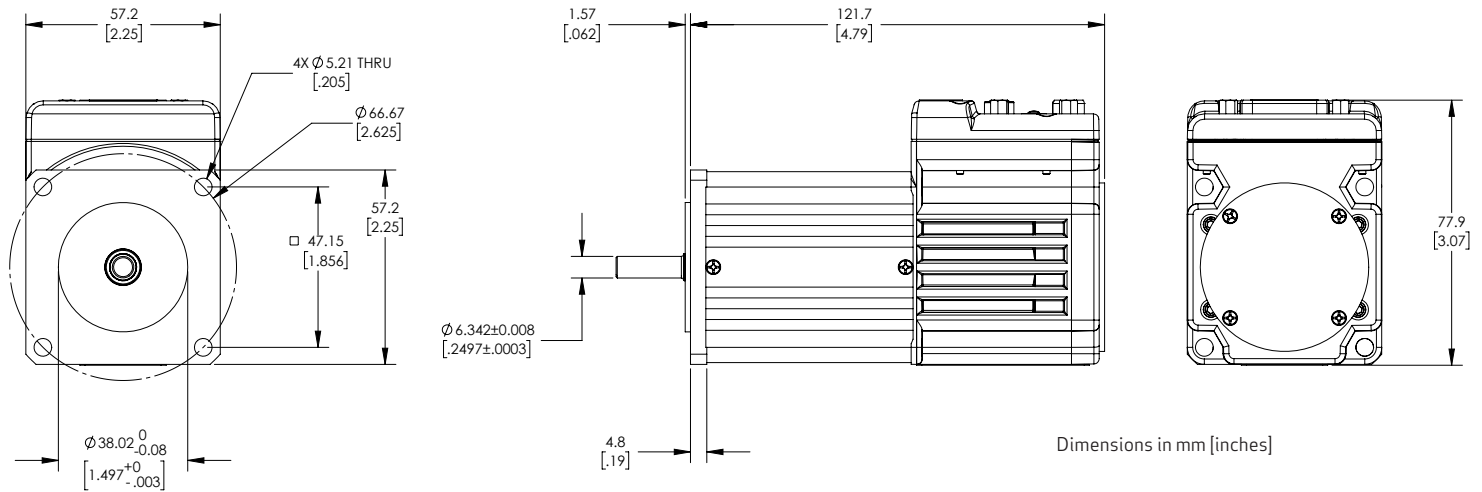

SM23266DT/SM23266DT w/Brake

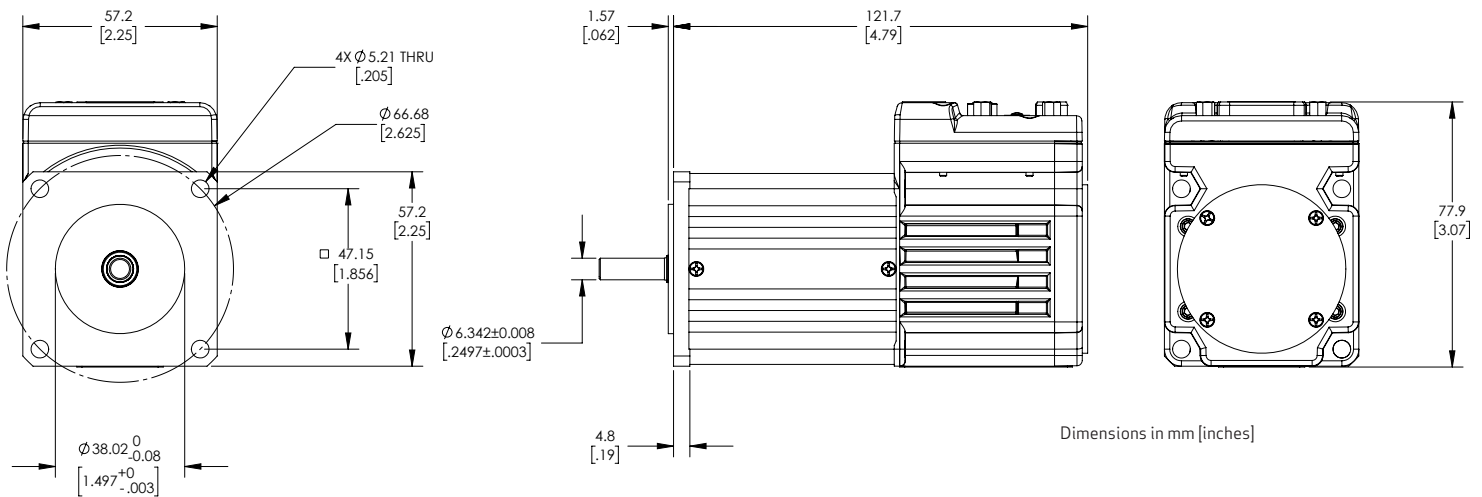

NOTE: Motor specifications are subject to changes without notice. Consult website and factory for latest data.

SPECIFICATIONS

OUTLINE DRAWINGS

SM17166D*

*Check with factory for availability

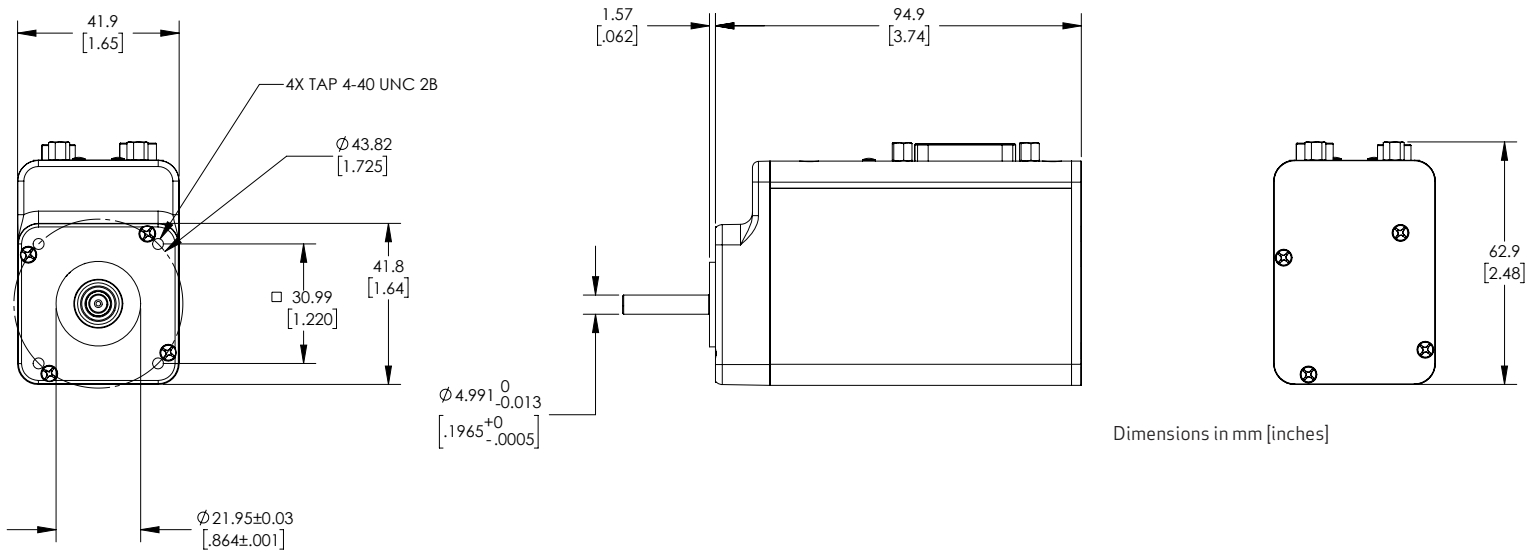

Dimensions in mm [inches]

SM34166DT

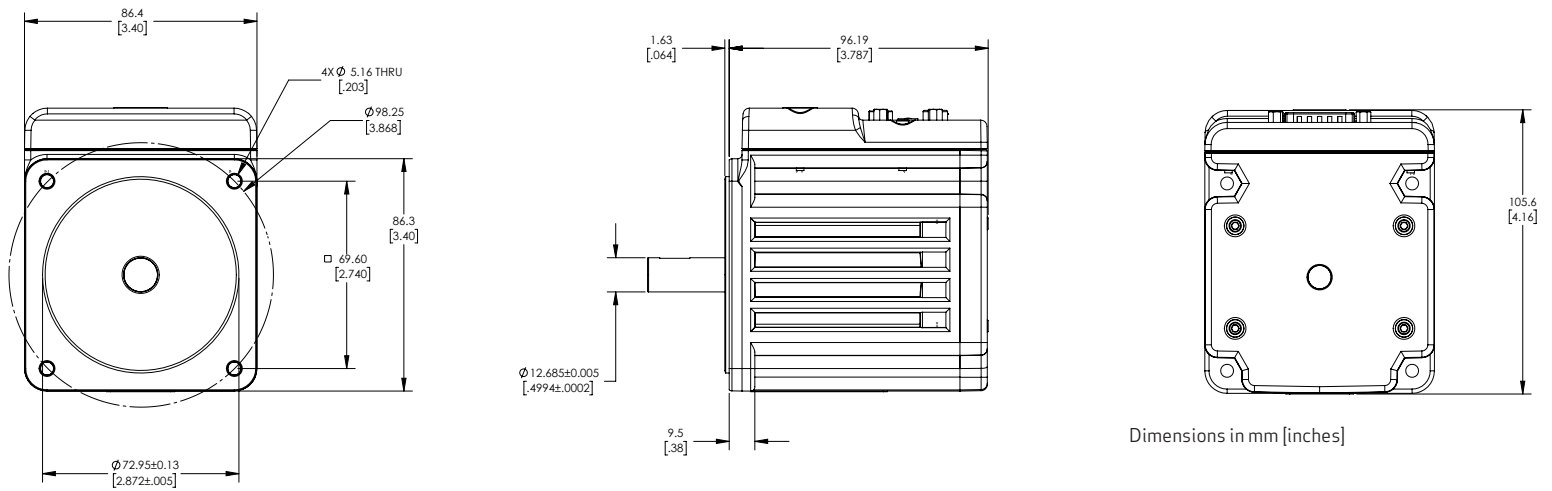

Dimensions in mm [inches]

SM34166DT w/Brake

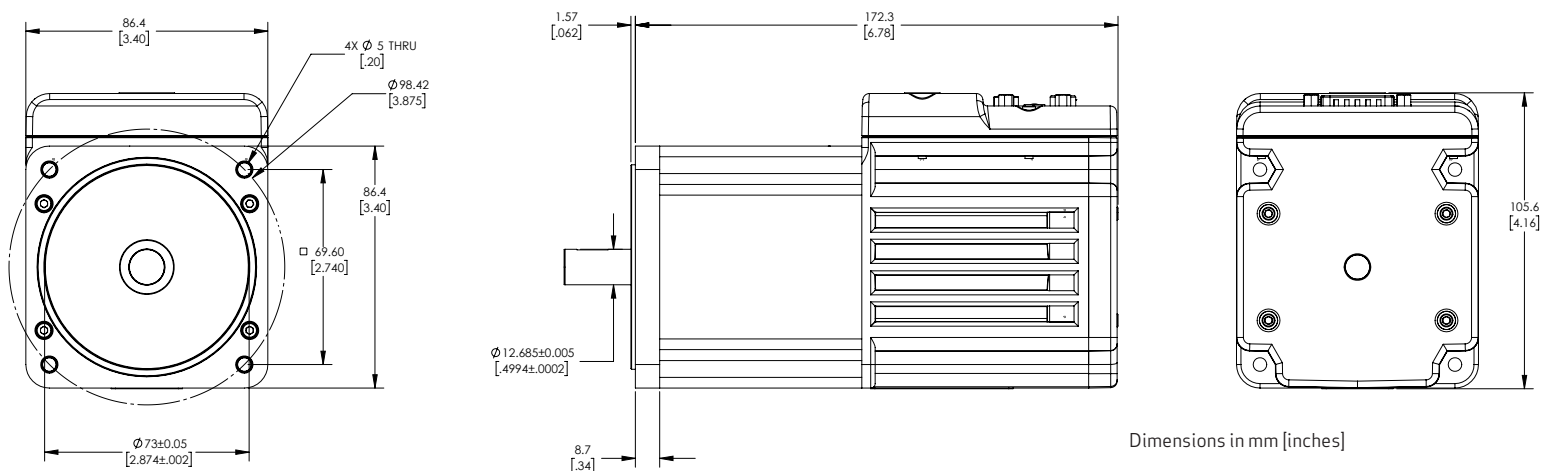

Dimensions in mm [inches]

NOTE: Motor specifications are subject to changes without notice. Consult website and factory for latest data.

SPECIFICATIONS

PERFORMANCE TORQUE POWER CURVES AND TECHNICAL DATA

SM23166D at 24 V at Rise to 105° C

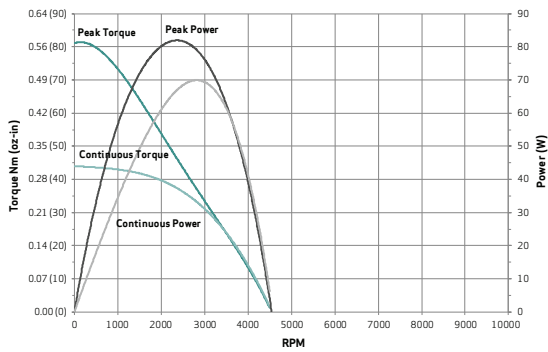

SM23166D at 48 V at Rise to 105° C

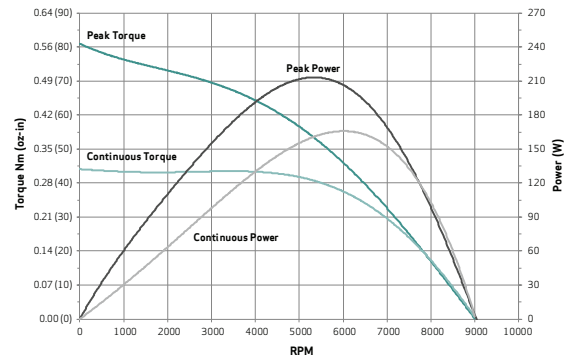

SM23166DT at 24 V at Rise to 105° C

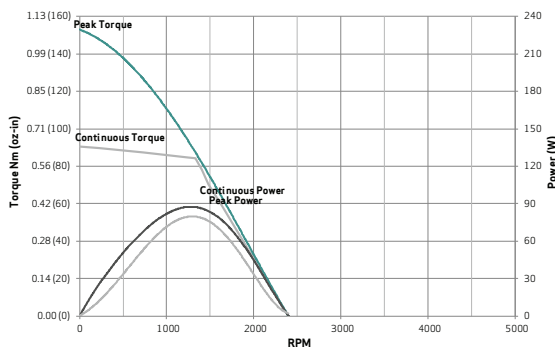

SM23166DT at 48 V at Rise to 105° C

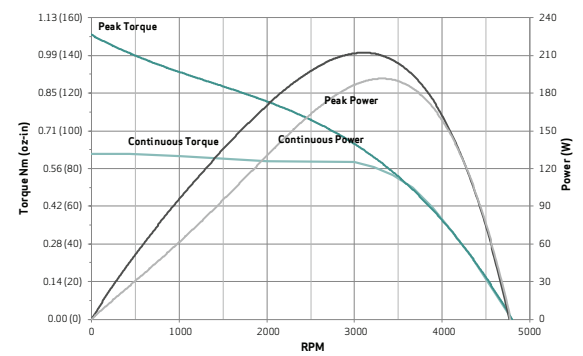

SM23376DT at 24 V at rise to 105° C

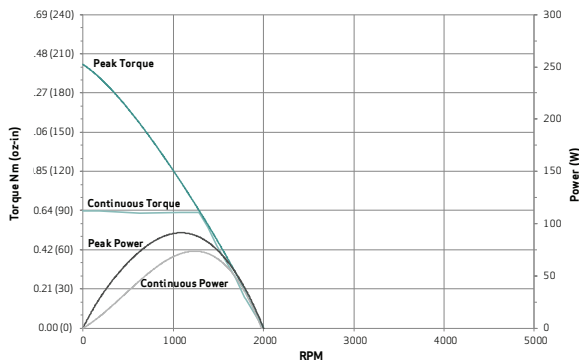

SM23376DT at 48 V at rise to 105° C

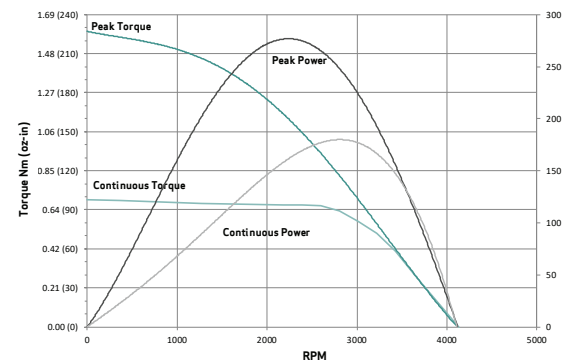

SM23266DT at 24 V at Rise to 105° C

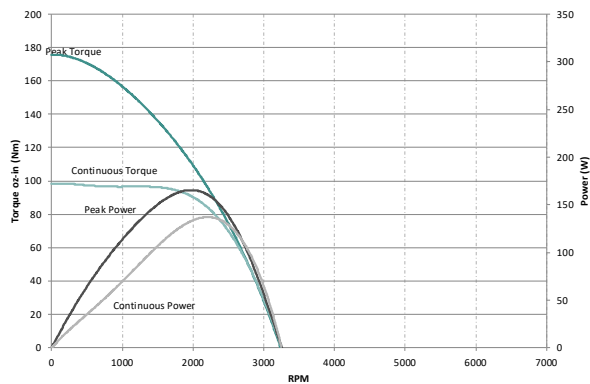

SM23266DT at 48 V at Rise to 105° C

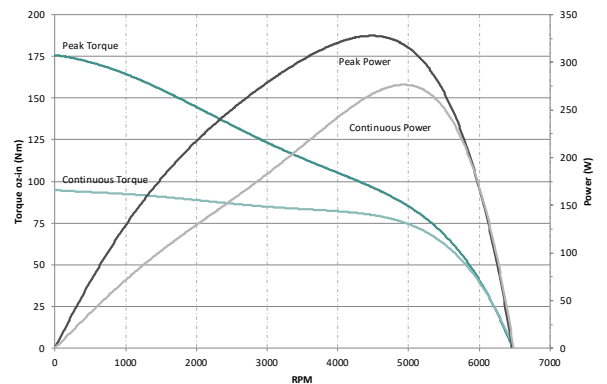

All torque curves based on 25° C ambient. For ambient temperatures above 25° C, continuous torque must be linearly derated to 0% at 100° C. Operating temperature range: from -20 to 100° C. Storage temperature range: from -20 to 105° C. Relative humidity: < 85%, noncondensing. Motors were operated using MDE (Enhanced Trapezoidal Drive Mode) commutation.

OPTIONS

	Options	Available
	Industrial Ethernet	2 Ethernet connections on back of the motor
	Fieldbus protocols	EtherNet/IP™ PROFINET® EtherCAT®
	Brake	Inline
	Standard on all models	DMX protocol Dual power (ability to power controller and drive separately) CANopen per CIA4.02 Combitronic™ communications over CANopen or EtherNet/IP™ CAN over D-Sub 7W2 (CDS7)

ETHERNET OPTION

For all motors with Ethernet connectors, add the dimensions of the following module on the back, to the overall mechanical dimensions:

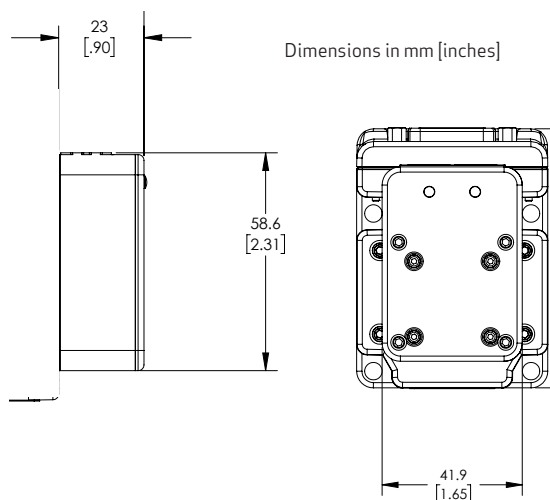

CONNECTORS

HD26-Pin D-Sub I/O

Top row: 9 8 7 6 5 4 3 2 1
Mid row: 18 17 16 15 14 13 12 11 10

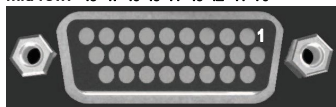

Bottom row: 26 25 24 23 22 21 20 19

Pin	Description
1	IN0 GP, Discrete or Analog
2	IN1 GP, Discrete or Analog
3	IN2 Positive Limit or GP
4	IN3 Negative Limit or GP
5	In/Out4 GP
6	In/Out5 GP
7	IN6, G CMD, Home In
8	IN7, Drive Enable Input
9	In/Out8, GP or Brake Out
10	In/Out9, GP or Not Fault Out
11	+24 VDC Control Power
12	Ground (Common)
13	Encoder A+ Input

Pin	Description
14	Encoder A- Input
15	Encoder B+ Input
16	Encoder B- Input
17	CAN High (Also on 7W2)
18	CAN Low (Also on 7W2)
19	RS-485 B (COM CH 1)
20	RS-485 A (COM CH 1)
21	4-20 mA Send
22	4-20 mA Return
23	USB 5 V Bus
24	USB D+
25	USB D-
26	Ground (Common)

7-Pin Combo D-Sub Power and I/O

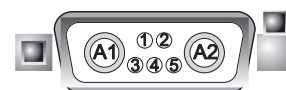

Pin	Description
A1	I+20 to +48 VDC
A2	Common Ground (Req'd. POWER Ground)
1	CAN Low (Also on HD26)
2	CAN High (Also on HD26)
3	RS-232 Transmit (COM CH 0)
4	RS-232 Receive (COM CH 0)
5	Common Ground (Typ. SIG Ground)

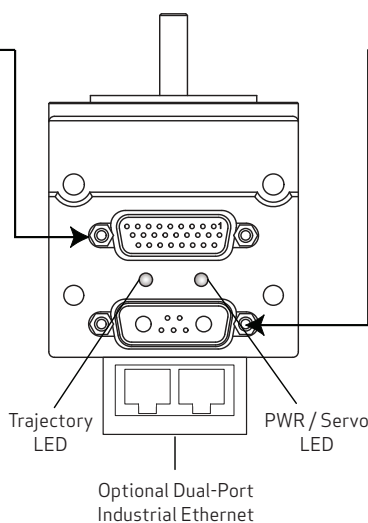

POWER CABLES AND ADAPTER

Power and Communication Cable (Flying Leads) for Main 7W2 Connector on the SmartMotor™

CBLPWRCOM3 series provides power along with RS-232 and CAN Bus communications in one convenient cable to simplify installation. It consists of a 7W2 main motor connector with RS-232 and CAN communications separately shielded from power, and a full shield over the entire length terminating at a metal jacket inside the over-molded connector.

Part Number	Length
CBLPWRCOM3-3M	3 meters
CBLPWRCOM3-5M	5 meters
CBLPWRCOM3-10M	10 meters

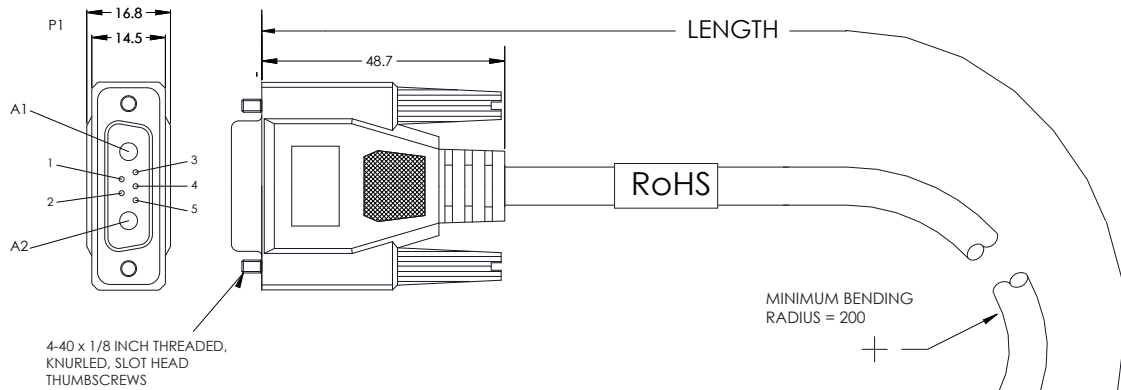
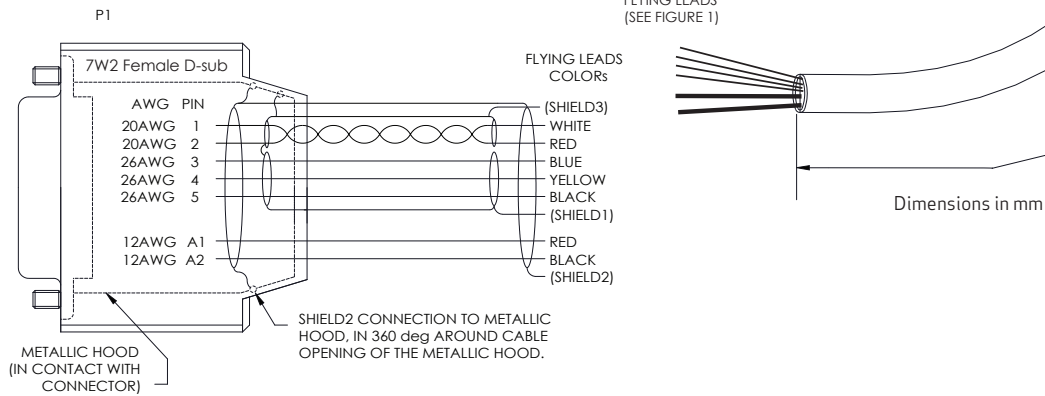

Figure 1: Pinout and Color Code



ACCESSORIES

POWER CABLES AND ADAPTER

CBLSMCDS-xM (Moog Animatics CDS7 "Add-A-Motor" Cable)

Power, RS-232 and CAN Bus Communications Daisy Chain Cable for Single-Cable Connections Between Multiple Moog Animatics SmartMotor™ Servos

CBLSMCDS series is the "Add-A-Motor" -style power and communications cable for a CDS7-equipped SmartMotor. It consists of a pass-thru 7W2 main motor connector split out to a single second motor 7W2 connector. This single cable is capable of carrying power, RS-232 and CAN Bus communications from motor to motor using only the 7W2 connector.

The CBLSMCDS cable is designed to allow ease of connection to multiple motors in a single daisy-chain network. The main power ground wire is a larger gauge to decrease noise emissions at the ground-plane level. All communications lines are internally shielded from the power lines.

Part Number	Length
CBLSMCDS-0.3	0.3 meters
CBLSMCDS-0.9	0.9 meters
CBLSMCDS-3.0	3 meters
CBLSMCDS-7.5	7.5 meters

The two end nodes of the CAN Bus network must be terminated with a 120 ohm terminator (shunt) for proper biasing. If an end node is a SmartMotor, a pass-thru terminator is available (PN: CBLSM-TR120) that attaches directly to the motor's 15-pin D-sub connector to serve as the terminator.

Figure 1

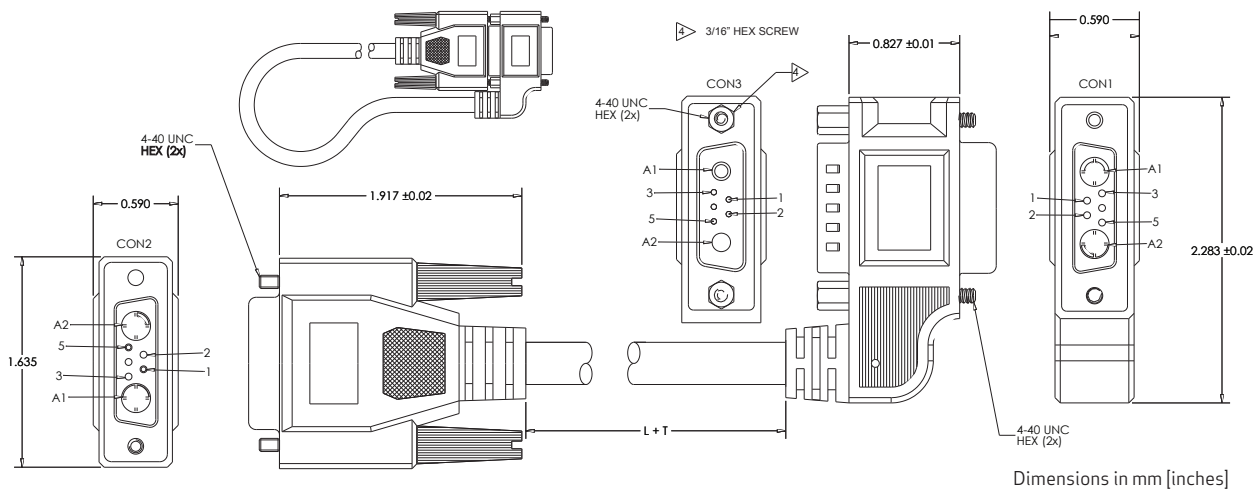
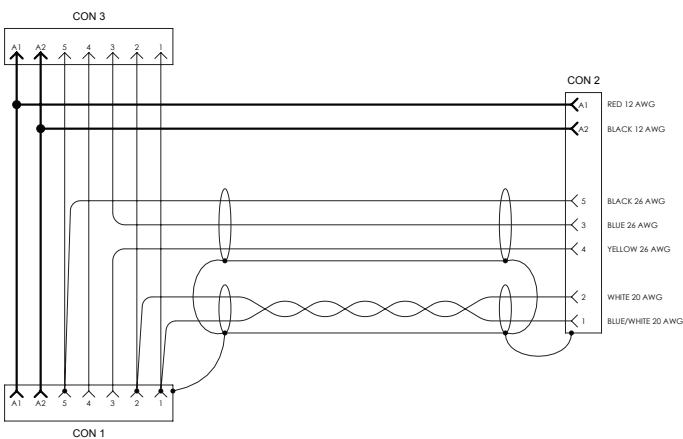

Figure 2



Connector Pinouts					
CON 3 Pin	AWG - Color / Stripe	CON 1 Pin	AWG - Color / Stripe	CON 2 Pin	Description
1	20 - Any	1	20 - Blue/White	1	CAN Bus Low
2	20 - Any	2	20 - White	2	CAN Bus High
3		NC	26 - Blue	3	RS-232 TX
NC		3	26 - Yellow	4	RS-232 Crossover
4	26 - Any	4		NC	RS-232 RX
5	26 - Any	5	26 - Black	5	Signal Return
A1	12 - Any	A1	*12 - Red	A1	Power
A2	12 - Any	A2	*12 - Black	A2	Ground

*CON 2 PIN A1 and A2 wires spliced to wires between CON 1 and 3.

Terminate 20/26 AWG shield drain wires to CON 1 and CON 2 as shown in Figure 2.

CAUTION: When using these cables with the larger 34 frame motors, please consult the factory for power limitations.

I/O ADAPTER

HD26 Cable Connector (PN: CBLHD26-ASM)

Part CBLHD26-ASM is available so that users can construct their own interface cable for the Class 6 D-style SmartMotor. The connector (with customer-supplied cable) attaches to the HD26 D-sub connector on the motor. The figure and table show the PCB connection points for the customer-supplied cable. A Micro USB port provides a convenient access point for programming from SMI.

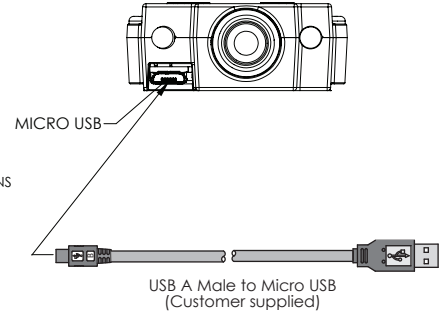
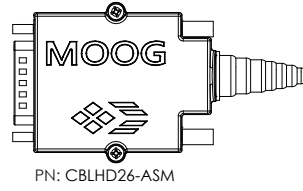
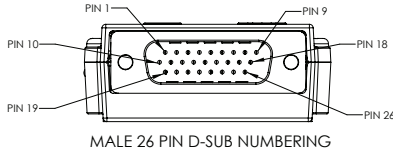

Part Number	Length
CBLHD26-ASM	Connector w/ PCB

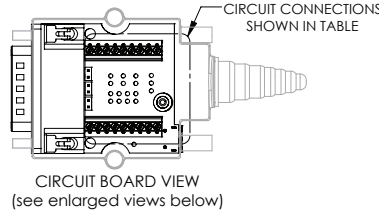

Connector Pinouts			
HD26 Pin No	Description	PCB Label	Recommended Wire AWG
-	SHIELD	SH	-
1	GPI 0	I0	26
2	GPI 1	I1	26
3	GPI 2	I2	26
4	GPI 3	I3	26
5	GPIO4	I04	26
6	GPIO5	I05	26
7	GPI 6	I6	26
8	GPI 7	I7	26
9	GPIO 8	O8	26
10	GPIO 9	O9	26
11	24 V	24 V	18
12	GND	RTN	18
13	USR ENC A+	A+	26
14	USR ENC A-	A-	26
15	USR ENC B+	B+	26
16	USR ENC B-	B-	26
17	CAN High	C_P	18
18	CAN Low	C_N	18
19	RS485 B	RS485 B	26
20	RS485 A	RS485 A	26
21	SEND 4-20 mA	4 - 20 S	26
22	RETURN 4-20 mA	4 - 20 R	26
23	USB VBUS	-	-
24	USB D +	-	-
25	USB D -	-	-
26	GND	-	-

PN: CBLHD26-ASM

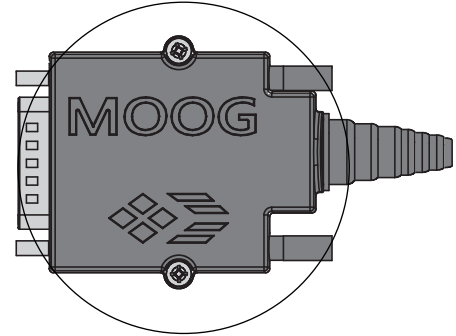

Cover removed to show internal PCB

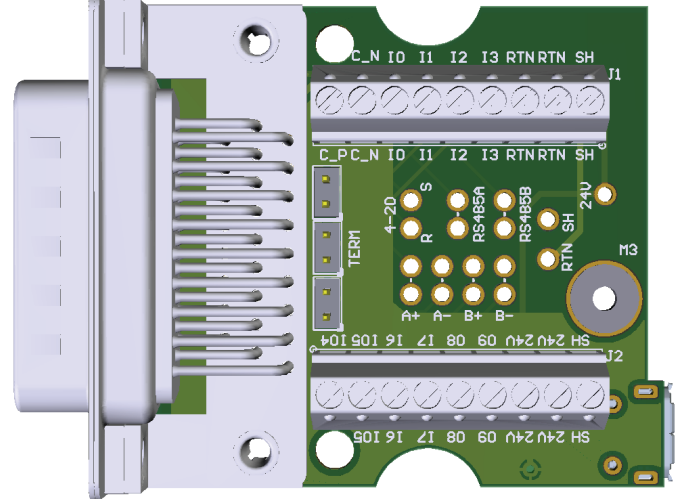

NOTES: Screw connections are provided for most commonly used signals.

Recommended wire gauge sizes for all screw terminal connections:

- 18 gauge for Control power (+24 V and RTN)
- 18 gauge twisted pair shielded for CAN High and CAN Low (CAN-P and CAN-N)
- 26 gauge for any I/O, not to exceed 200 mA for any single channel output

Recommended wire gauge sizes for solder pad connections:

- 26 gauge twisted pair shielded for RS-485 (RS-485A and RS-485B)
- 26 gauge twisted pair shielded for each A and B encoder input (A+ / A-, B+ / B-)
- 26 gauge pair for 4-20 mA Analog input

While it is expected that users will develop their own interface cables based on application needs, Moog can supply cable wire at specified lengths. Please contact the factory for more information.

Extra power connection points are provided for +24 V and RTN through screw terminals and solder pads; these are for use with local sensors and travel limits.

Shield drain wire connections should be terminated only on one end of any shielded cable used.

The shield connection to this board terminates to the HD26 connector shell only. When plugged into the motor, the connector shell will connect to the motor chassis only; it is not (and should never be) connected to either the drive or control power return lines.

A USB connection is only allowed through the included Micro USB port; there is no other external access on this adapter. The USB port is used to program from SMI; it is not recommended for running the motor.

PART NUMBERING GUIDELINES

ORDERING CODE

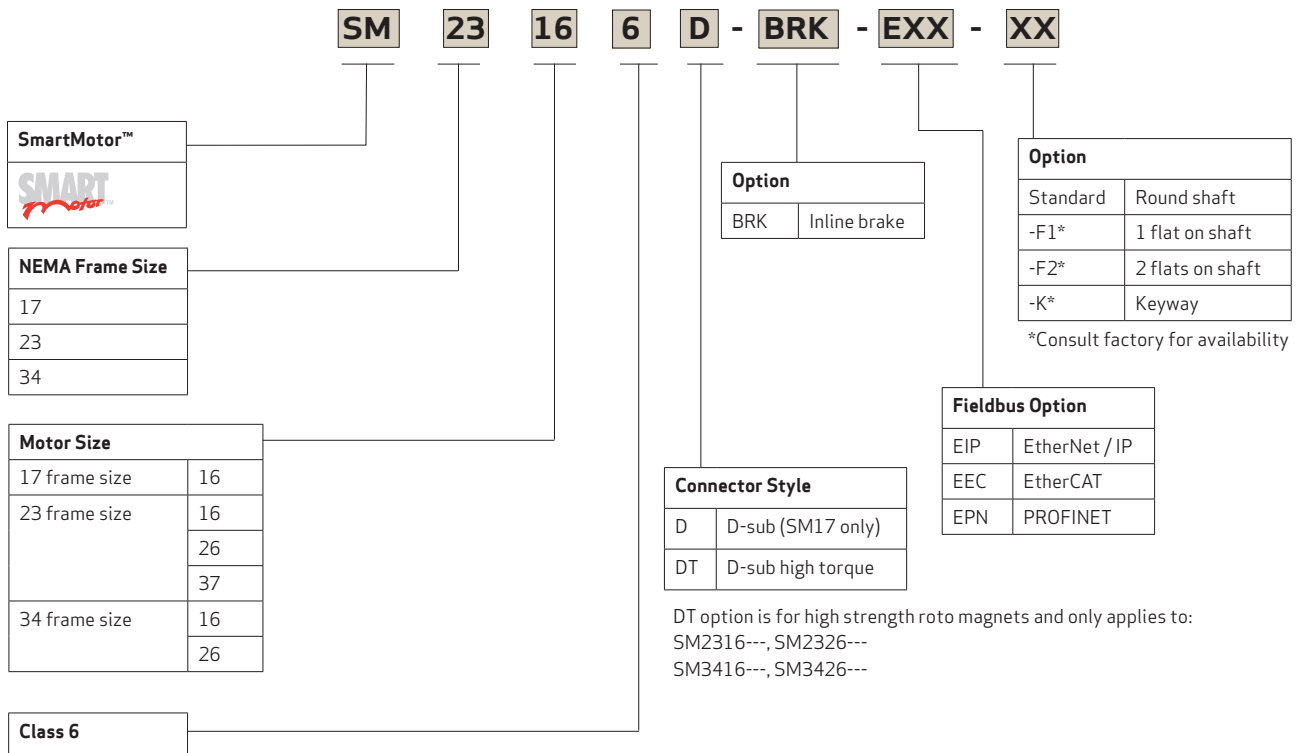

For product information, visit www.animatics.com

For more information or the office nearest you, contact us online, animatics_sales@moog.com

Moog is a registered trademark of Moog Inc. and its subsidiaries.
All trademarks as indicated herein are the property of Moog Inc. and its subsidiaries.
©2022 Moog Inc. All rights reserved. All changes are reserved.

Moog Animatics Class 6 D-Style SmartMotor™ Technical Data Sheet
MCM/Rev. E, April 2022, Id. CDL65512-en