

# VIPA System SLIO

**IM | 053-1MT00 | Manual**

HB300 | IM | 053-1MT00 | GB | 14-26

VIPA GmbH  
Ohmstr. 4  
91074 Herzogenaurach  
Telephone: +49 9132 744-0  
Fax: +49 9132 744-1864  
email: [info@vipa.com](mailto:info@vipa.com)  
Internet: [www.vipa.com](http://www.vipa.com)

## Table of contents

<b>1</b>	<b>General</b> .....	<b>4</b>
1.1	Copyright © VIPA GmbH .....	4
1.2	About this manual.....	5
1.3	Safety information.....	6
<b>2</b>	<b>Basics and Assembly</b> .....	<b>8</b>
2.1	Safety information for users.....	8
2.2	System conception.....	9
2.3	Dimensions.....	12
2.4	Installation.....	13
2.5	Demounting and module exchange.....	18
2.6	Wiring.....	22
2.7	Trouble shooting - LEDs.....	26
2.8	Installation guidelines.....	26
2.9	General data.....	29
<b>3</b>	<b>Hardware description</b> .....	<b>31</b>
3.1	Properties.....	31
3.2	Structure.....	32
3.2.1	Interfaces.....	32
3.2.2	LEDs.....	33
3.3	Technical data.....	34
<b>4</b>	<b>Deployment</b> .....	<b>37</b>
4.1	Basics.....	37
4.2	Access to the Ethernet coupler.....	39
4.2.1	Overview.....	39
4.2.2	SPEED7 Modbus Tool.....	40
4.2.3	Web page.....	40
4.2.4	C-/Socket programming.....	44
4.2.5	Modbus utility.....	45
4.3	Accessing the System SLIO.....	45
4.3.1	Overview.....	45
4.3.2	Address-Mapping.....	46
4.3.3	Accessing I/O area .....	47
4.3.4	Accessing parameter data.....	47
4.3.5	Accessing diagnostics data.....	47
4.4	Modbus/TCP.....	48
4.5	Modbus function codes.....	49
4.6	Register allocation.....	55
4.7	LED status indication.....	56

# 1 General

## 1.1 Copyright © VIPA GmbH

### All Rights Reserved

This document contains proprietary information of VIPA and is not to be disclosed or used except in accordance with applicable agreements.

This material is protected by the copyright laws. It may not be reproduced, distributed, or altered in any fashion by any entity (either internal or external to VIPA), except in accordance with applicable agreements, contracts or licensing, without the express written consent of VIPA and the business management owner of the material.

For permission to reproduce or distribute, please contact: VIPA, Gesellschaft für Visualisierung und Prozessautomatisierung mbH Ohmstraße 4, D-91074 Herzogenaurach, Germany

Tel.: +49 9132 744 -0

Fax.: +49 9132 744-1864

E-Mail: [info@vipa.de](mailto:info@vipa.de)

<http://www.vipa.com>



*Every effort has been made to ensure that the information contained in this document was complete and accurate at the time of publishing. Nevertheless, the authors retain the right to modify the information.*

*This customer document describes all the hardware units and functions known at the present time. Descriptions may be included for units which are not present at the customer site. The exact scope of delivery is described in the respective purchase contract.*

### CE Conformity Declaration

Hereby, VIPA GmbH declares that the products and systems are in compliance with the essential requirements and other relevant provisions. Conformity is indicated by the CE marking affixed to the product.

### Conformity Information

For more information regarding CE marking and Declaration of Conformity (DoC), please contact your local VIPA customer service organization.

**Trademarks**

VIPA, SLIO, System 100V, System 200V, System 300V, System 300S, System 400V, System 500S and Commander Compact are registered trademarks of VIPA Gesellschaft für Visualisierung und Prozessautomatisierung mbH.

SPEED7 is a registered trademark of profichip GmbH.

SIMATIC, STEP, SINEC, TIA Portal, S7-300 and S7-400 are registered trademarks of Siemens AG.

Microsoft and Windows are registered trademarks of Microsoft Inc., USA.

Portable Document Format (PDF) and Postscript are registered trademarks of Adobe Systems, Inc.

All other trademarks, logos and service or product marks specified herein are owned by their respective companies.

**Information product support**

Contact your local VIPA Customer Service Organization representative if you wish to report errors or questions regarding the contents of this document. If you are unable to locate a customer service centre, contact VIPA as follows:

VIPA GmbH, Ohmstraße 4, 91074 Herzogenaurach, Germany

Telefax: +49 9132 744-1204

E-Mail: [documentation@vipa.de](mailto:documentation@vipa.de)

**Technical support**

Contact your local VIPA Customer Service Organization representative if you encounter problems with the product or have questions regarding the product. If you are unable to locate a customer service centre, contact VIPA as follows:

VIPA GmbH, Ohmstraße 4, 91074 Herzogenaurach, Germany

Tel.: +49 9132 744-1150 (Hotline)

E-Mail: [support@vipa.de](mailto:support@vipa.de)

**1.2 About this manual****Objective and contents**

This manual describes the IM 053-1MT00 of the System SLIO from VIPA. It contains a description of the structure, project engineering and deployment. This manual is part of the documentation package with order number VIPA HB300E\_IM and relevant for:

Product	Order number	as of state:	
		HW	FW
IM 053MT	053-1MT00	01	V1.1.2

**Target audience**

The manual is targeted at users who have a background in automation technology.

**Structure of the manual**

The manual consists of chapters. Every chapter provides a self-contained description of a specific topic.

- Guide to the document** The following guides are available in the manual:
- An overall table of contents at the beginning of the manual
  - References with page numbers
- Availability** The manual is available in:
- printed form, on paper
  - in electronic form as PDF-file (Adobe Acrobat Reader)
- Icons Headings** Important passages in the text are highlighted by following icons and headings:

**DANGER!**

Immediate or likely danger. Personal injury is possible.

**CAUTION!**

Damages to property is likely if these warnings are not heeded.



*Supplementary information and useful tips.*

### 1.3 Safety information

#### Applications conforming with specifications

The System SLIO is constructed and produced for:

- communication and process control
- general control and automation applications
- industrial applications
- operation within the environmental conditions specified in the technical data
- installation into a cubicle

**DANGER!**

This device is not certified for applications in  
– in explosive environments (EX-zone)

#### Documentation

The manual must be available to all personnel in the

- project design department
- installation department
- commissioning
- operation

**CAUTION!**

**The following conditions must be met before using or commissioning the components described in this manual:**

- Hardware modifications to the process control system should only be carried out when the system has been disconnected from power!
- Installation and hardware modifications only by properly trained personnel.
- The national rules and regulations of the respective country must be satisfied (installation, safety, EMC ...)

**Disposal**

**National rules and regulations apply to the disposal of the unit!**

## 2 Basics and Assembly

### 2.1 Safety information for users

#### Handling of electrostatic sensitive modules

VIPA modules make use of highly integrated components in MOS-Technology. These components are extremely sensitive to over-voltages that can occur during electrostatic discharges. The following symbol is attached to modules that can be destroyed by electrostatic discharges.



The Symbol is located on the module, the module rack or on packing material and it indicates the presence of electrostatic sensitive equipment. It is possible that electrostatic sensitive equipment is destroyed by energies and voltages that are far less than the human threshold of perception. These voltages can occur where persons do not discharge themselves before handling electrostatic sensitive modules and they can damage components thereby, causing the module to become inoperable or unusable. Modules that have been damaged by electrostatic discharges can fail after a temperature change, mechanical shock or changes in the electrical load. Only the consequent implementation of protection devices and meticulous attention to the applicable rules and regulations for handling the respective equipment can prevent failures of electrostatic sensitive modules.

#### Shipping of modules

Modules must be shipped in the original packing material.

#### Measurements and alterations on electrostatic sensitive modules

When you are conducting measurements on electrostatic sensitive modules you should take the following precautions:

- Floating instruments must be discharged before use.
- Instruments must be grounded.

Modifying electrostatic sensitive modules you should only use soldering irons with grounded tips.



#### CAUTION!

Personnel and instruments should be grounded when working on electrostatic sensitive modules.



## 2.2 System conception

### Overview

System SLIO is a modular automation system for assembly on a 35mm mounting rail. By means of the peripheral modules with 2, 4 or 8 channels this system may properly be adapted matching to your automation tasks. The wiring complexity is low, because the supply of the DC 24V power section is integrated to the backplane bus and defective modules may be replaced with standing wiring. By deployment of the power modules in contrasting colours within the system, further isolated areas may be defined for the DC 24V power section supply, respectively the electronic power supply may be extended with 2A.

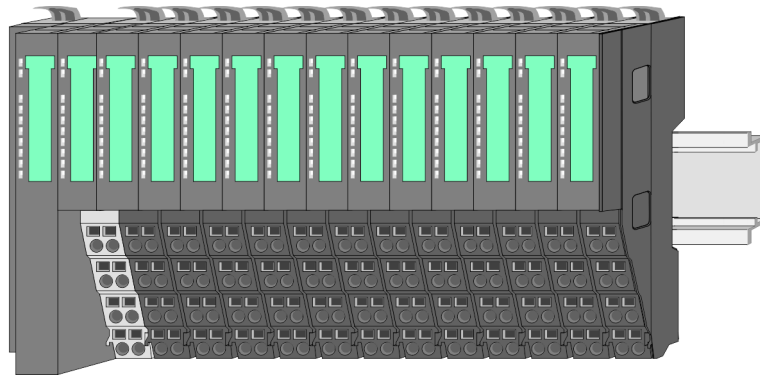

### Components

- CPU (head module)
- Bus coupler (head module)
- Periphery modules
- Power modules
- Accessories



#### CAUTION!

Only modules of VIPA may be combined. A mixed operation with third-party modules is not allowed!

### CPU



With a CPU, CPU electronic and power module are integrated to one casing. As head module via the integrated power module for power supply the CPU electronic is supplied as well as the electronic of the connected periphery modules. The DC 24 power section supply for the linked periphery modules is established via a further connection at the power module. By installing of up to 64 periphery modules at the CPU, these are electrically connected, this means these are assigned to the backplane bus, the electronic modules are power supplied and each periphery module is connected to the DC 24V power section supply.



#### CAUTION!

CPU part and power module of a CPU may not be separated! Here you may only exchange the electronic module!

**Bus coupler**

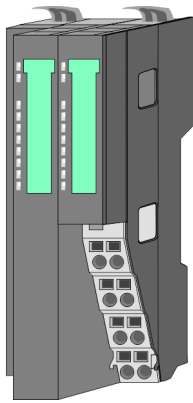

With a bus coupler bus interface and power module are integrated to one casing. With the bus interface you get access to a subordinated bus system. As head module via the integrated power module for power supply the bus interface is supplied as well as the electronic of the connected periphery modules. The DC 24 power section supply for the linked periphery modules is established via a further connection at the power module. By installing of up to 64 periphery modules at the bus coupler, these are electrically connected, this means these are assigned to the backplane bus, the electronic modules are power supplied and each periphery module is connected to the DC 24V power section supply.



**CAUTION!**

Bus interface and power module of the bus coupler may not be separated! Here you may only exchange the electronic module!

**Periphery modules**

Each periphery module consists of a *terminal* and an *electronic module*.

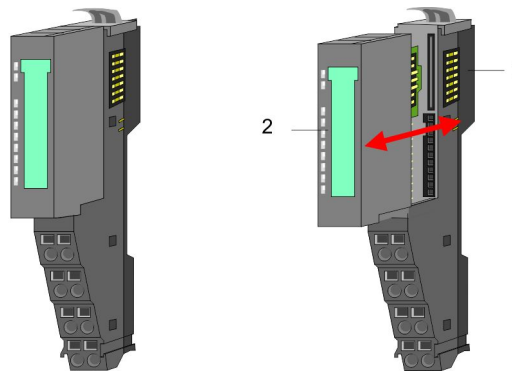

- 1 Terminal module
- 2 Electronic module

**Terminal module**

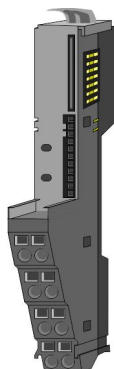

The *terminal module* serves to carry the electronic module, contains the backplane bus with power supply for the electronic, the DC 24V power section supply and the staircase-shaped terminal for wiring. Additionally the terminal module has a locking system for fixing at a mounting rail. By means of this locking system your SLIO system may be assembled outside of your switchgear cabinet to be later mounted there as whole system.

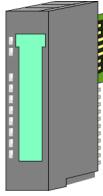
**Electronic module**

The functionality of a SLIO peripheral module is defined by the *electronic module*, which is mounted to the terminal module by a safe sliding mechanism. With an error the defective module may be exchanged for a functional module with standing installation.

At the front side there are LEDs for status indication. For simple wiring each module shows a corresponding connection diagram at the front and at the side.

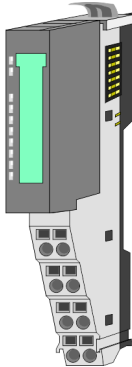
**Power module**

In the System SLIO the power supply is established by power modules. These are either integrated to the bus coupler or may be installed between the peripheral modules. Depending on the power module isolated areas of the DC 24V power section supply may be defined respectively the electronic power supply may be extended with 2A. For better recognition the colour of the power modules are contrasting to the periphery modules.

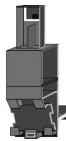
**Accessories****Shield bus carrier**

The shield bus carrier (order no. 000-0AB00) serves to carry the shield bus (10mm x 3mm) to connect cable shields. Shield bus carriers, shield bus and shield fixings are not in the scope of delivery. They are only available as accessories.

The shield bus carrier is mounted underneath the terminal of the terminal module. With a flat mounting rail for adaption to a flat mounting rail you may remove the spacer of the shield bus carrier.

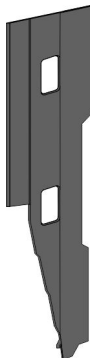
**Bus cover**

With each bus coupler, to protect the backplane bus connectors, there is a mounted bus cover in the scope of delivery. You have to remove the bus cover of the bus coupler before mounting a SLIO module. For the protection of the backplane bus connector you always have to mount the bus cover at the last module of your system again.

The bus cover has the order no. 000-0AA00.

**Coding pins**



There is the possibility to fix the assignment of electronic and terminal module. Here coding pins (order number 000-0AC00) from VIPA can be used.

The coding pin consists of a coding jack and a coding plug. By combining electronic and terminal module with coding pin, the coding jack remains in the electronic module and the coding plug in the terminal module.

This ensures that after replacing the electronics module just another electronic module can be plugged with the same encoding.

**2.3 Dimensions**

**Dimensions CPU**

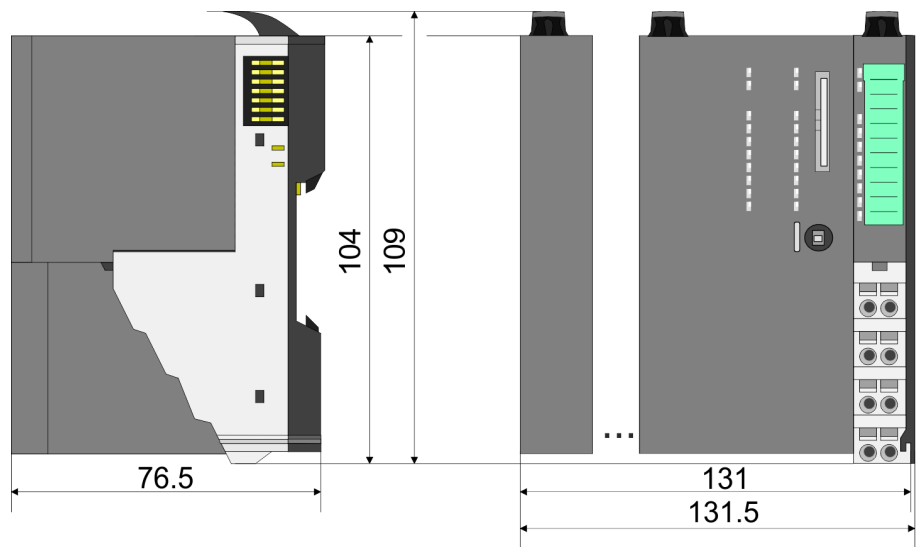

**Dimensions bus coupler**

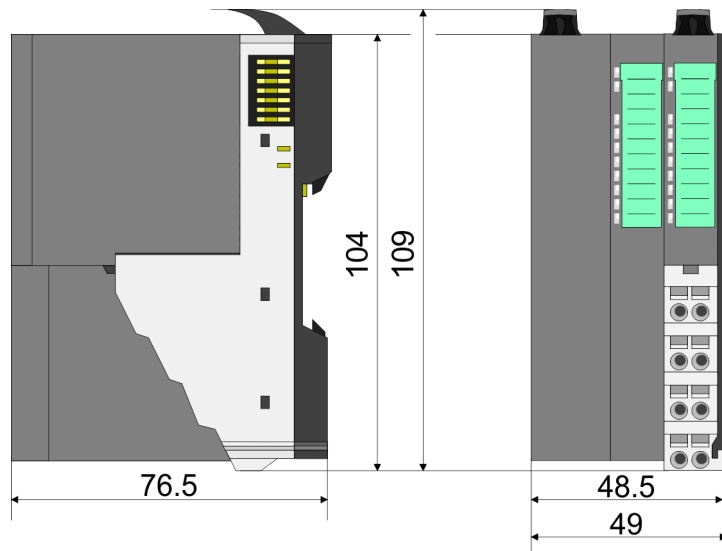

**Dimensions periphery module**

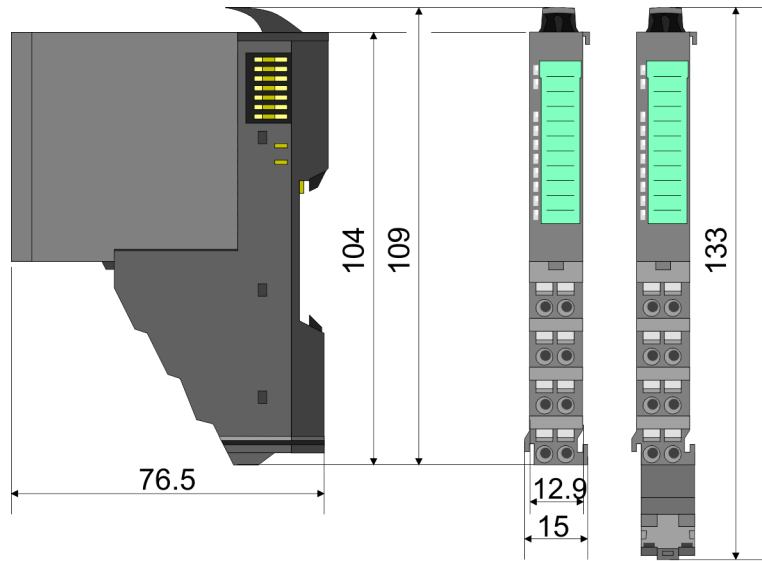

**Dimensions electronic module**

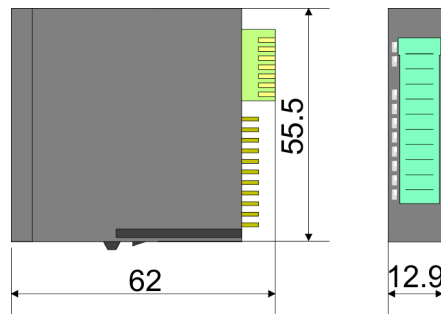

Dimensions in mm

**2.4 Installation**

**Functional principle**

There is a locking lever at the top side of the terminal module. For mounting and demounting this locking lever is to be turned upwards until this engages audible. Now the module may be pulled forward. For mounting plug the module to the module installed before and push the module to the mounting rail guided by the strips at the upper and lower side of the module. The module is fixed to the mounting rail by pushing downward the locking lever. The modules may either separately be mounted to the mounting rail or as block. Here is to be considered that each locking lever is opened.

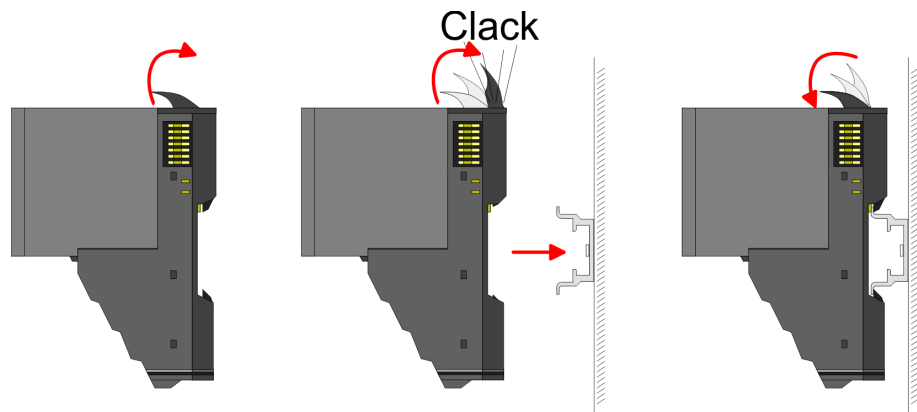

For the exchange of a electronic module, the electronic module may be pulled forward after pressing the unlocking lever at the lower side of the module. For installation plug the electronic module guided by the strips at the lower side until this engages audible to the terminal module.

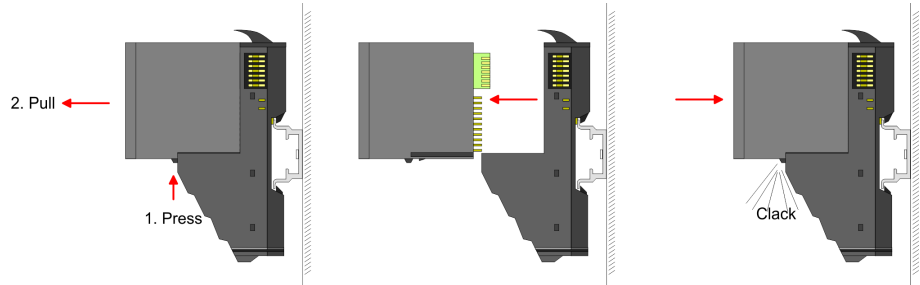

**Coding**



There is the possibility to fix the assignment of electronic and terminal module. Here coding pins (order number 000-0AC00) from VIPA can be used. The coding pin consists of a coding jack and a coding plug. By combining electronic and terminal module with coding pin, the coding jack remains in the electronic module and the coding plug in the terminal module. This ensures that after replacing the electronics module just another electronic module can be plugged with the same encoding.

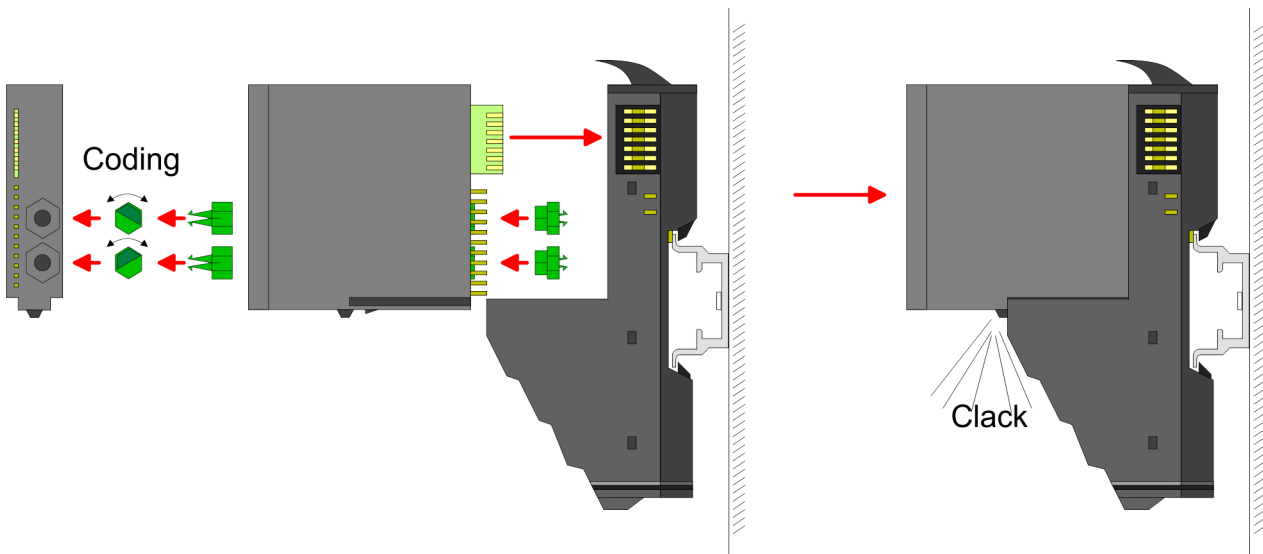

Each electronic module has on its back 2 coding sockets for coding jacks. Due to the characteristics, with the coding jack 6 different positions can be plugged, each. Thus there are 36 possible combinations for coding with the use of both coding sockets.

1. ► Plug, according to your coding, 2 coding jacks in the coding sockets of your electronic module until they lock.
2. ► Now plug the according coding plugs into the coding jacks.
3. ► To fix the coding put both the electronic and terminal module together until they lock.

**CAUTION!**

Please consider that when replacing an already coded electronic module, this is always be replaced by an electronic module with the same coding.

Even with an existing coding on the terminal module, you can plug an electronic module without coding. The user is responsible for the correct usage of the coding pins. VIPA assumes no liability for incorrectly attached electronic modules or for damages which arise due to incorrect coding!

**Mounting Proceeding**

The modules were directly be mounted to the mounting rail and so connected to the backplane bus and the power supply for the electronic and power section. Up to 64 modules may be mounted. Please consider here that the sum current of the electronic power supply does not exceed the maximum value of 3A. By means of the power module 007-1AB10 the current of the electronic power supply may be expanded with 2A. ↪ *Chapter 2.6 'Wiring' on page 22*

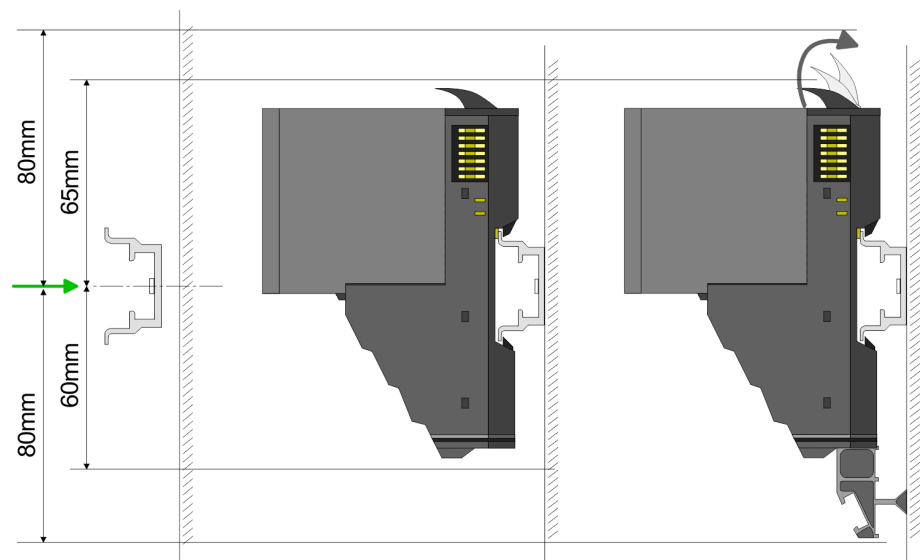
**Mounting rail**

- ➔ Mount the mounting rail! Please consider that a clearance from the middle of the mounting rail of at least 80mm above and 60mm below, respectively 80mm by deployment of shield bus carriers, exist.

Mounting Head module (e.g. bus coupler)

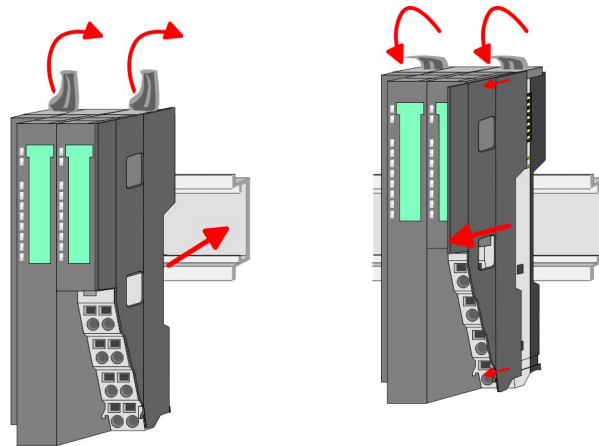

1. ▶ Start at the left side with the head module (e.g. bus coupler). For this turn both locking lever upwards, put the head module to the mounting rail and turn both locking lever downward.
2. ▶ Before mounting the periphery modules you have to remove the bus cover at the right side of the Head module by pulling it forward. Keep the cover for later mounting.

Mounting periphery modules

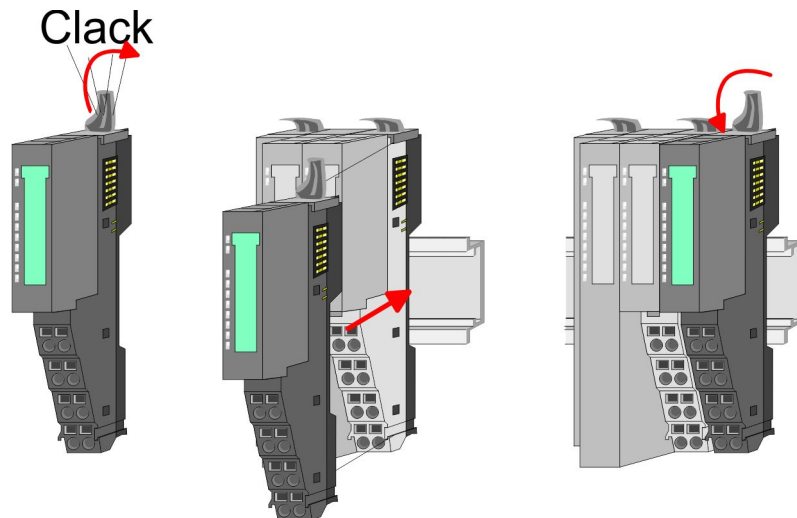

- ▶ Mount the periphery modules you want.



Mounting the bus cover

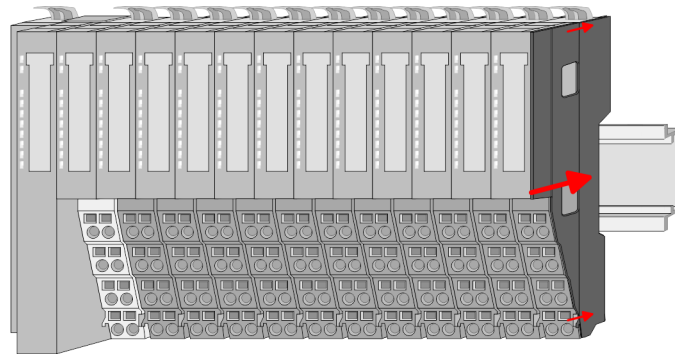

- ➔ After mounting the whole system, to protect the backplane bus connectors at the last module you have to mount the bus cover, now.

Mounting the bus cover at a clamp module

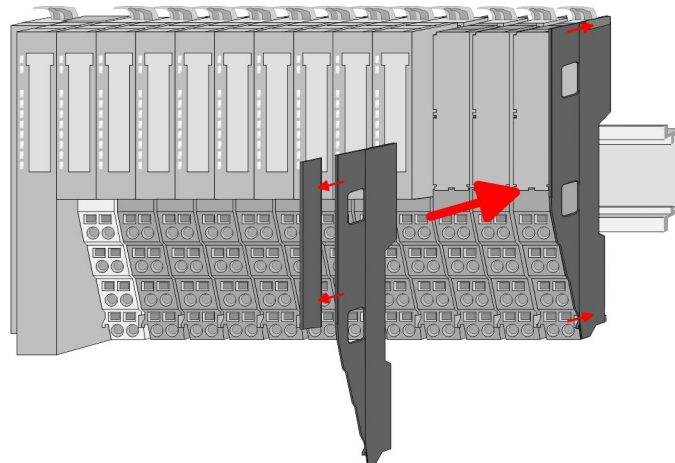

- ➔ If the last module is a clamp module, for adaptation the upper part of the bus cover is to be removed

Mounting shield bus carrier

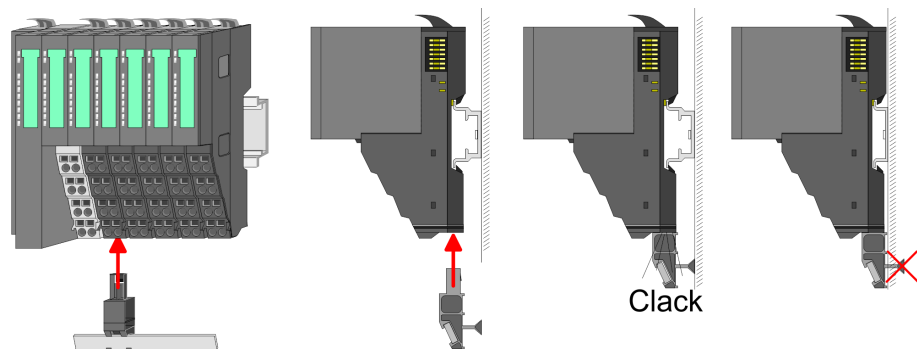

- ➔ The shield bus carrier (available as accessory) serves to carry the shield bus to connect cable shields. The shield bus carrier is mounted underneath the terminal of the terminal module. With a flat mounting rail for adaption to a flat mounting rail you may remove the spacer of the shield bus carrier.

## 2.5 Demounting and module exchange

### Proceeding

With demounting and exchange of a module, head module (e.g. bus coupler) or a group of modules for mounting reasons you have always to remove the electronic module of the just mounted right module. After the mounting it may be plugged again.

#### Exchange of an electronic module

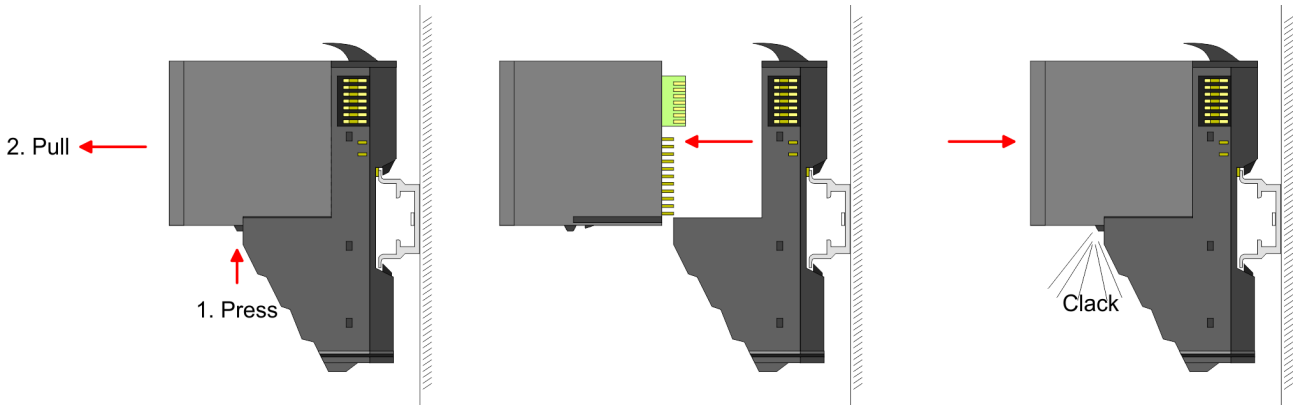

1. ➤ For the exchange of an electronic module, the electronic module may be pulled forward after pressing the unlocking lever at the lower side of the module.
2. ➤ For installation plug the electronic module guided by the strips at the lower side until this engages audible to the terminal module.

#### Exchange of a module

1. ➤ Remove if exists the wiring. ↪ *Chapter 2.6 'Wiring' on page 22.*

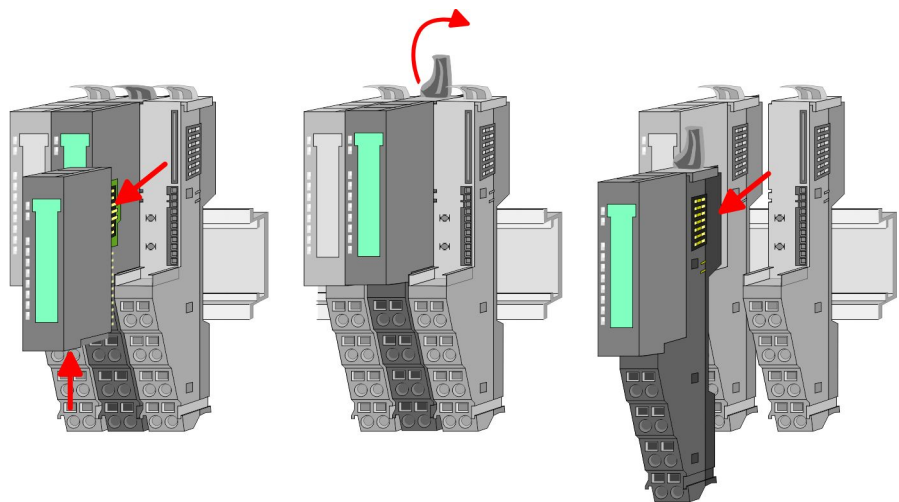

2. ➤ Press the unlocking lever at the lower side of the just mounted right module and pull it forward.
3. ➤ Turn the locking lever of the module to be exchanged upwards.
4. ➤ Pull the module forward.

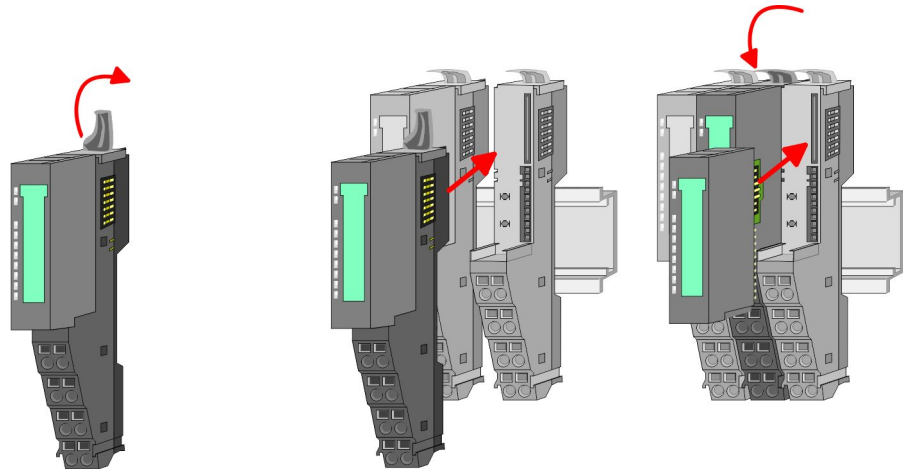

5. ▶ For mounting turn the locking lever of the module to be mounted upwards.
6. ▶ To mount the module put it to the gap between the both modules and push it, guided by the stripes at both sides, to the mounting rail.
7. ▶ Turn the locking lever downward again.
8. ▶ Plug again the electronic module, which you have removed before.

Exchange of a head module (e.g. bus coupler)



**CAUTION!**

Bus interface and power module of a head module may not be separated!

Here you may only exchange the electronic module!

1. ▶ Remove if exists the wiring of the head module. ↪ *Chapter 2.6 'Wiring' on page 22.*

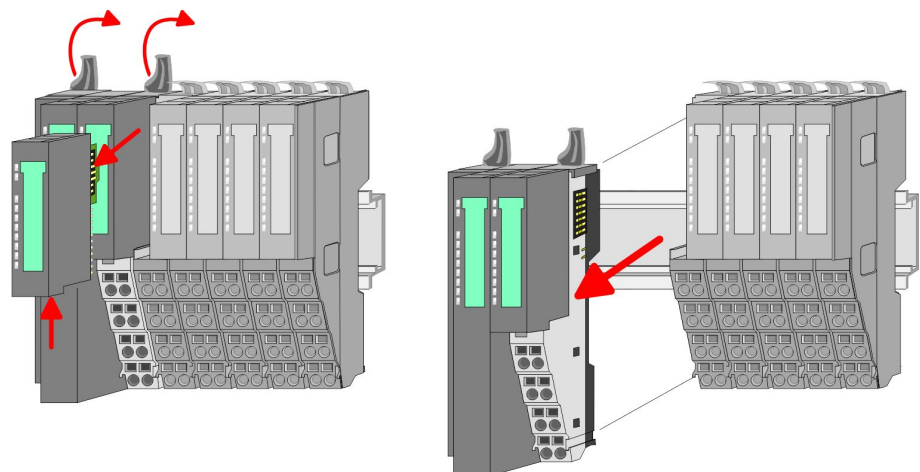

2. ▶ Press the unlocking lever at the lower side of the just mounted right module and pull it forward.
3. ▶ Turn all the locking lever of the head module to be exchanged upwards.
4. ▶ Pull the head module forward.

Demounting and module exchange

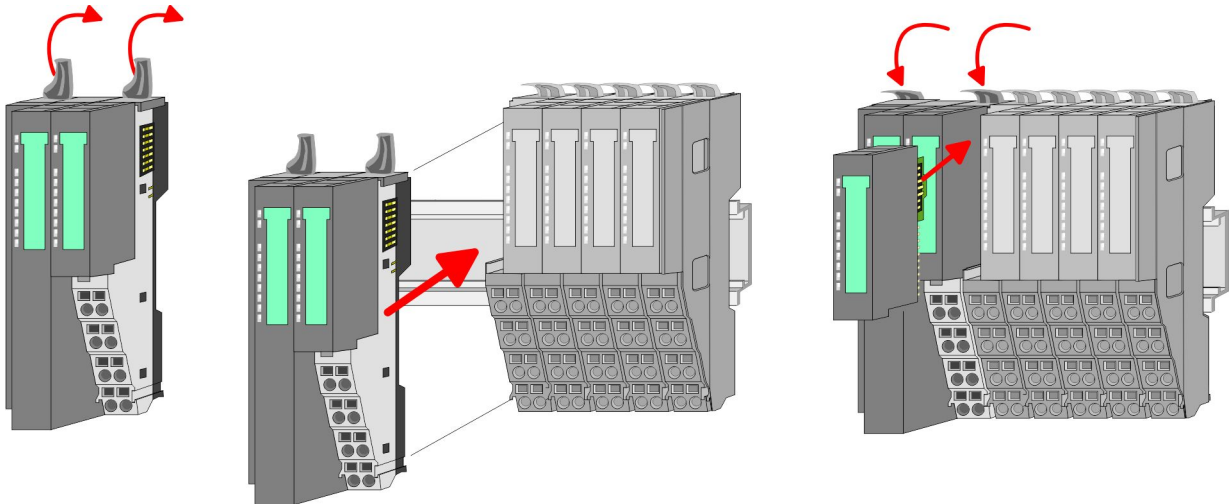

5. ▶ For mounting turn all the locking lever of the head module to be mounted upwards.
6. ▶ To mount the head module put it to the left module and push it, guided by the stripes, to the mounting rail.
7. ▶ Turn all the locking lever downward again.
8. ▶ Plug again the electronic module, which you have removed before.

Exchange of a module group

1. ▶ Remove if exists the wiring of the module group. ↪ *Chapter 2.6 'Wiring' on page 22.*

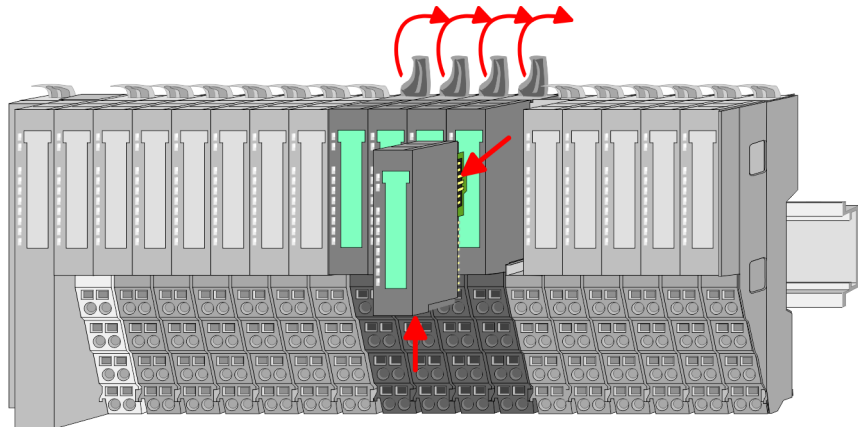

2. ▶ Press the unlocking lever at the lower side of the just mounted right module of the module group and pull it forward.

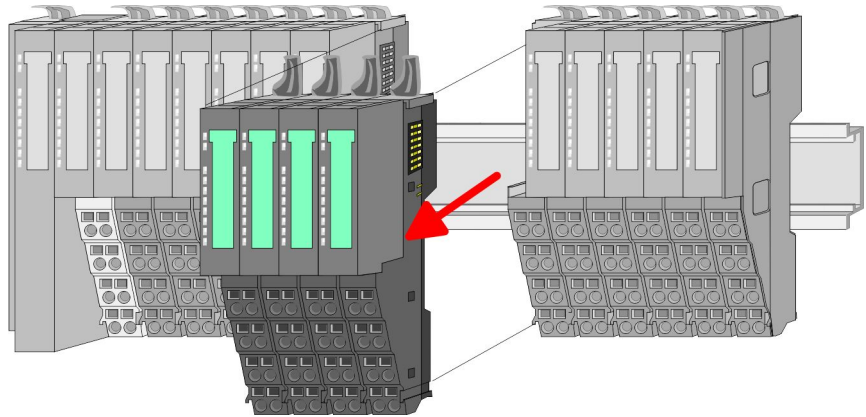

3. Turn all the locking lever of the module group to be exchanged upwards.
4. Pull the module group forward.

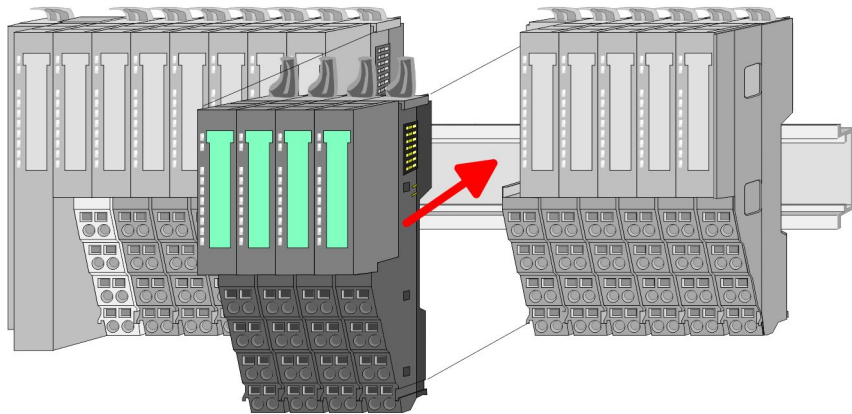
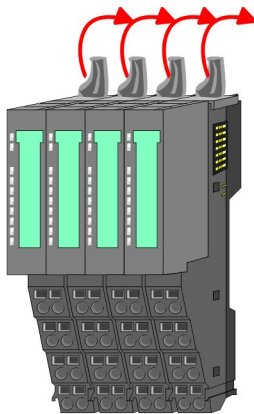

5. For mounting turn all the locking lever of the module group to be mounted upwards.
6. To mount the module group put it to the gap between the both modules and push it, guided by the stripes at both sides, to the mounting rail.

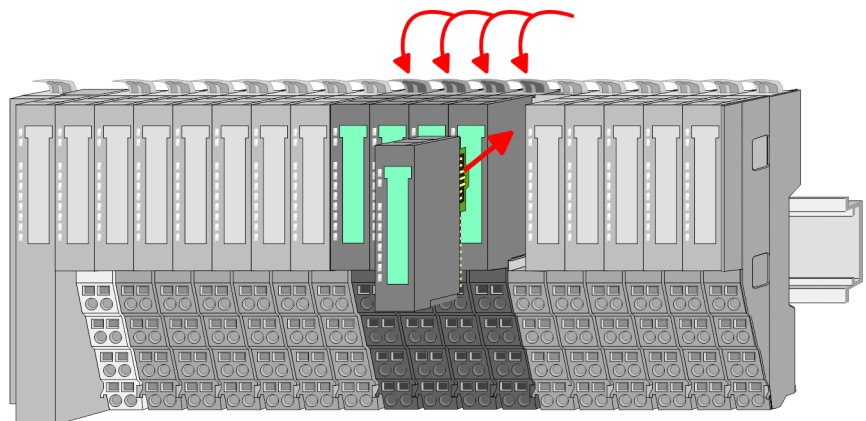

7. Turn all the locking lever downward again.
8. Plug again the electronic module, which you have removed before.

## 2.6 Wiring

### Connectors

Terminals with spring clamp technology are used for wiring.

The spring clamp technology allows quick and easy connection of your signal and supply lines.

In contrast to screw terminal connections this type of connection is vibration proof.

### Data

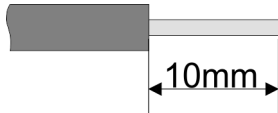

$U_{max}$ : 240V AC / 30V DC

$I_{max}$ : 10A

Cross section: 0.08 ... 1.5mm<sup>2</sup> (AWG 28 ... 16)

Stripping length: 10mm

### Wiring procedure

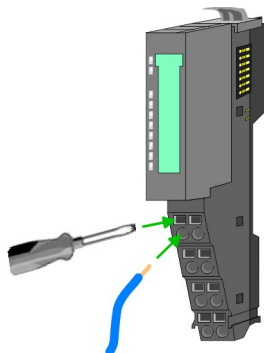
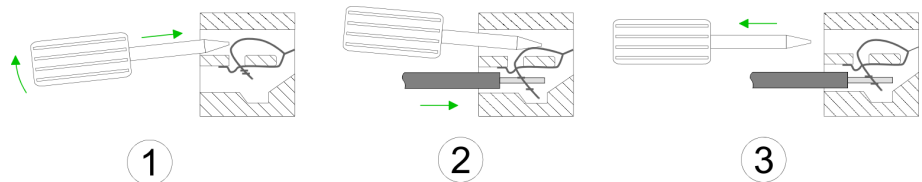

- 1.** ▶ Insert a suited screwdriver at an angle into the square opening as shown. Press and hold the screwdriver in the opposite direction to open the contact spring.
- 2.** ▶ Insert the stripped end of wire into the round opening. You can use wires with a cross section of 0.08mm<sup>2</sup> to 1.5mm<sup>2</sup>.
- 3.** ▶ By removing the screwdriver, the wire is securely fixed via the spring contact to the terminal.

Standard wiring

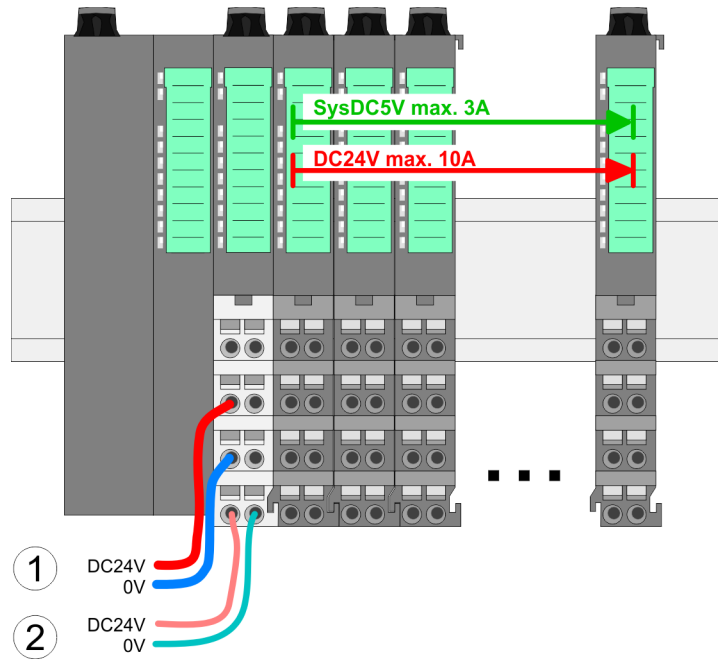

- (1) DC 24V for power section supply I/O area (max 10A)
- (2) DC 24V for electronic power supply bus coupler and I/O area

PM - Power module

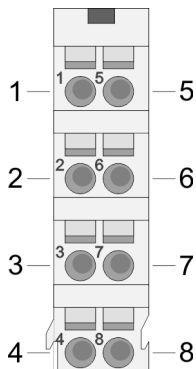

For wires with a core cross-section of 0.08mm<sup>2</sup> up to 1.5mm<sup>2</sup>.

Pos.	Function	Type	Description
1	---	---	not connected
2	DC 24V	I	DC 24V for power section supply
3	0V	I	GND for power section supply
4	Sys DC 24V	I	DC 24V for electronic section supply
5	---	---	not connected
6	DC 24V	I	DC 24V for power section supply
7	0V	I	GND for power section supply
8	Sys 0V	I	GND for electronic section supply

I Input



**CAUTION!**

Since the power section supply is not internally protected, it is to be externally protected with a fuse, which corresponds to the maximum current. This means max. 10A is to be protected by a 10A fuse (fast) respectively by a line circuit breaker 10A characteristics Z!



*The electronic power section supply is internally protected against higher voltage by fuse. The fuse is within the power module. If the fuse releases, its electronic module must be exchanged!*

**Fusing**

- The power section supply is to be externally protected with a fuse, which corresponds to the maximum current. This means max. 10A is to be protected with a 10A fuse (fast) respectively by a line circuit breaker 10A characteristics Z!
- It is recommended to externally protect the electronic power supply for bus coupler and I/O area with a 2A fuse (fast) respectively by a line circuit breaker 2A characteristics Z.
- The electronic power supply for the I/O area of the power module 007-1AB10 should also be externally protected with a 1A fuse (fast) respectively by a line circuit breaker 1A characteristics Z.

**State of the electronic power supply via LEDs**

After PowerON of the System SLIO the LEDs RUN respectively MF get on so far as the sum current does not exceed 3A.

With a sum current greater than 3A the LEDs may not be activated.

Here the power module with the order number 007-1AB10 is to be placed between the peripheral modules.

**Deployment of the power modules**

If the 10A for the power section supply is no longer sufficient, you may use the power module from VIPA with the order number 007-1AB00. So you have also the possibility to define isolated groups.

The power module with the order number 007-1AB10 is to be used if the 3A for the electronic power supply at the backplane bus is no longer sufficient. Additionally you get an isolated group for the DC 24V power section supply with 4A.

By placing the power module 007-1AB10 at the following backplane bus modules may be placed with a sum current of max. 2A. Afterwards the power module 007-1AB10 is to be placed again. To secure the power supply, the power modules may be mixed used.

**Power module 007-1AB00**

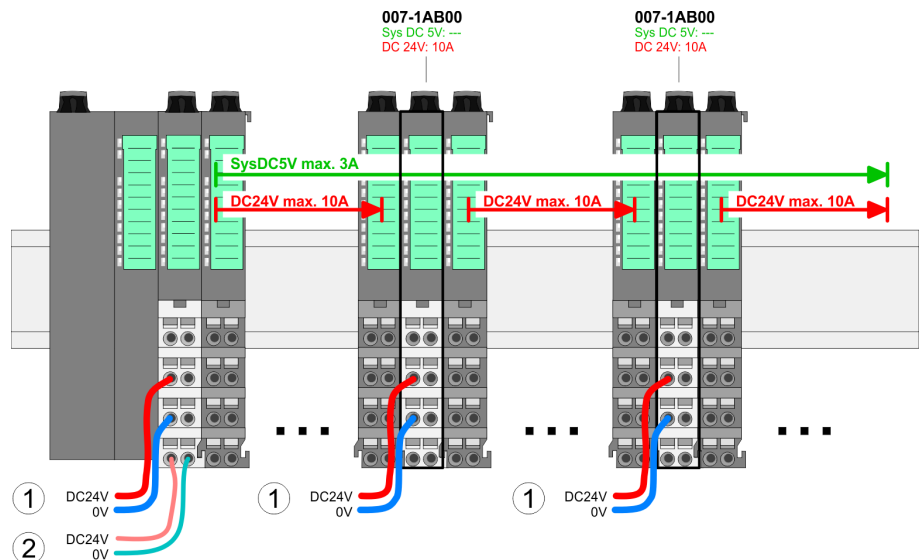



**Power module  
007-1AB10**

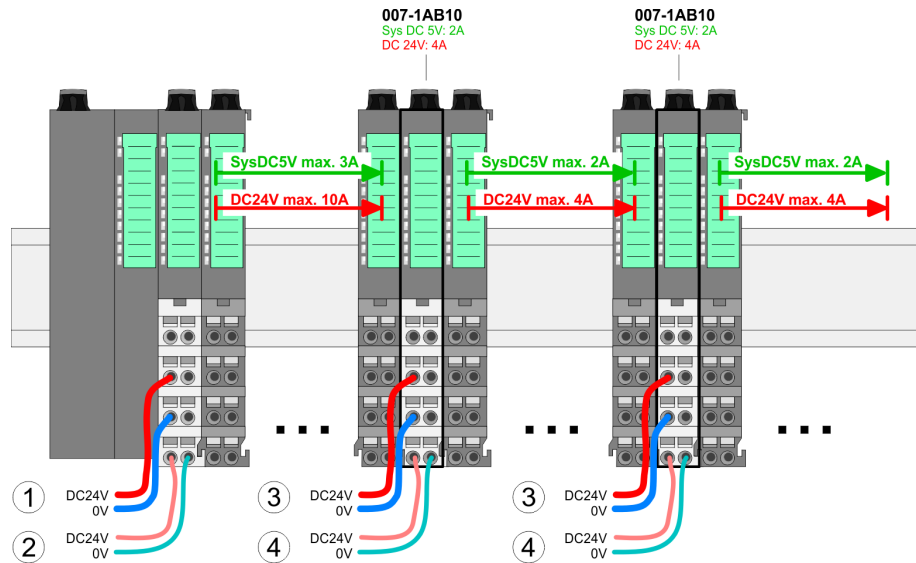

- (1) DC 24V for power section supply I/O area (max. 10A)
- (2) DC 24V for electronic power supply bus coupler and I/O area
- (3) DC 24V for power section supply I/O area (max. 4A)
- (4) DC 24V for electronic power supply I/O area

**Shield attachment**

To attach the shield the mounting of shield bus carriers are necessary.

The shield bus carrier (available as accessory) serves to carry the shield bus to connect cable shields.

The shield bus carrier is mounted underneath the terminal of the terminal module. With a flat mounting rail for adaption to a flat mounting rail you may remove the spacer of the shield bus carrier.

After mounting the shield bus carrier with the shield bus, the cables with the accordingly stripped cable screen may be attached and fixed by the shield clamp.

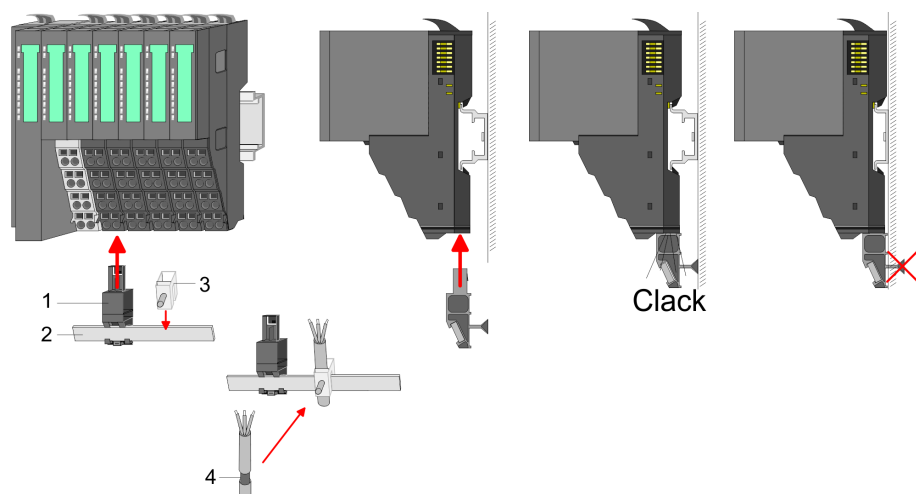

- 1 Shield bus carrier
- 2 Shield bus (10mm x 3mm)
- 3 Shield clamp
- 4 Cable shield

## 2.7 Trouble shooting - LEDs

### General

Each module has the LEDs RUN and MF on its front side. Errors or incorrect modules may be located by means of these LEDs.

In the following illustrations flashing LEDs are marked by ☼.

### Sum current of the electronic power supply exceeded

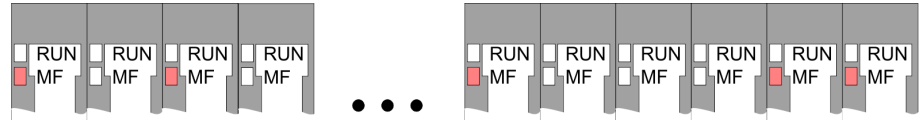

**Behaviour:** After PowerON the RUN LED of each module is off and the MF LED of each module is sporadically on.

**Reason:** The maximum current for the electronic power supply is exceeded.

**Remedy:** As soon as the sum current of the electronic power supply is exceeded, always place the power module 007-1AB10.

↳ Chapter 2.6 'Wiring' on page 22.

### Error in configuration

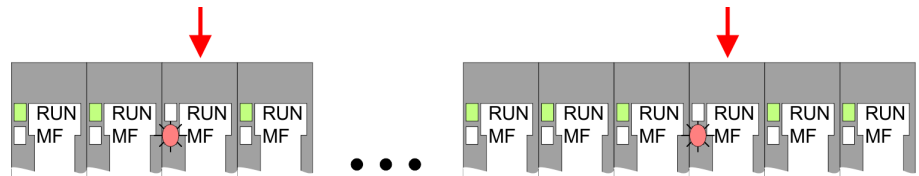

**Behaviour:** After PowerON the MF LED of one module respectively more modules flashes. The RUN LED remains off.

**Reason:** At this position a module is placed, which does not correspond to the configured module.

**Remedy:** Match configuration and hardware structure.

### Module failure

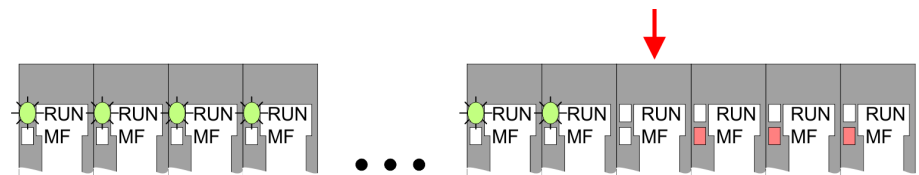

**Behaviour:** After PowerON all of the RUN LEDs up to the defective module are flashing. With all following modules the MF LED is on and the RUN LED is off.

**Reason:** The module on the right of the flashing modules is defective.

**Remedy:** Replace the defective module.

## 2.8 Installation guidelines

### General

The installation guidelines contain information about the interference free deployment of a PLC system. There is the description of the ways, interference may occur in your PLC, how you can make sure the electromagnetic compatibility (EMC), and how you manage the isolation.

- What does EMC mean?** Electromagnetic compatibility (EMC) means the ability of an electrical device, to function error free in an electromagnetic environment without being interfered respectively without interfering the environment.
- The components of VIPA are developed for the deployment in industrial environments and meets high demands on the EMC. Nevertheless you should project an EMC planning before installing the components and take conceivable interference causes into account.
- Possible interference causes** Electromagnetic interferences may interfere your control via different ways:
- Electromagnetic fields (RF coupling)
  - Magnetic fields with power frequency
  - Bus system
  - Power supply
  - Protected earth conductor
- Depending on the spreading medium (lead bound or lead free) and the distance to the interference cause, interferences to your control occur by means of different coupling mechanisms.
- There are:
- galvanic coupling
  - capacitive coupling
  - inductive coupling
  - radiant coupling
- Basic rules for EMC** In the most times it is enough to take care of some elementary rules to guarantee the EMC. Please regard the following basic rules when installing your PLC.
- Take care of a correct area-wide grounding of the inactive metal parts when installing your components.
    - Install a central connection between the ground and the protected earth conductor system.
    - Connect all inactive metal extensive and impedance-low.
    - Please try not to use aluminium parts. Aluminium is easily oxidizing and is therefore less suitable for grounding.
  - When cabling, take care of the correct line routing.
    - Organize your cabling in line groups (high voltage, current supply, signal and data lines).
    - Always lay your high voltage lines and signal respectively data lines in separate channels or bundles.
    - Route the signal and data lines as near as possible beside ground areas (e.g. suspension bars, metal rails, tin cabinet).
  - Proof the correct fixing of the lead isolation.
    - Data lines must be laid isolated.
    - Analog lines must be laid isolated. When transmitting signals with small amplitudes the one sided laying of the isolation may be favourable.
    - Lay the line isolation extensively on an isolation/protected earth conductor rail directly after the cabinet entry and fix the isolation with cable clamps.
    - Make sure that the isolation/protected earth conductor rail is connected impedance-low with the cabinet.
    - Use metallic or metallised plug cases for isolated data lines.

- In special use cases you should appoint special EMC actions.
  - Consider to wire all inductivities with erase links.
  - Please consider luminescent lamps can influence signal lines.
- Create a homogeneous reference potential and ground all electrical operating supplies when possible.
  - Please take care for the targeted employment of the grounding actions. The grounding of the PLC serves for protection and functionality activity.
  - Connect installation parts and cabinets with your PLC in star topology with the isolation/protected earth conductor system. So you avoid ground loops.
  - If there are potential differences between installation parts and cabinets, lay sufficiently dimensioned potential compensation lines.

### Isolation of conductors

Electrical, magnetically and electromagnetic interference fields are weakened by means of an isolation, one talks of absorption. Via the isolation rail, that is connected conductive with the rack, interference currents are shunt via cable isolation to the ground. Here you have to make sure, that the connection to the protected earth conductor is impedance-low, because otherwise the interference currents may appear as interference cause.

When isolating cables you have to regard the following:

- If possible, use only cables with isolation tangle.
- The hiding power of the isolation should be higher than 80%.
- Normally you should always lay the isolation of cables on both sides. Only by means of the both-sided connection of the isolation you achieve high quality interference suppression in the higher frequency area. Only as exception you may also lay the isolation one-sided. Then you only achieve the absorption of the lower frequencies. A one-sided isolation connection may be convenient, if:
  - the conduction of a potential compensating line is not possible.
  - analog signals (some mV respectively  $\mu\text{A}$ ) are transferred.
  - foil isolations (static isolations) are used.
- With data lines always use metallic or metallised plugs for serial couplings. Fix the isolation of the data line at the plug rack. Do not lay the isolation on the PIN 1 of the plug bar!
- At stationary operation it is convenient to strip the insulated cable interruption free and lay it on the isolation/protected earth conductor line.
- To fix the isolation tangles use cable clamps out of metal. The clamps must clasp the isolation extensively and have well contact.
- Lay the isolation on an isolation rail directly after the entry of the cable in the cabinet. Lead the isolation further on to your PLC and don't lay it on there again!



#### **CAUTION!**

#### **Please regard at installation!**

At potential differences between the grounding points, there may be a compensation current via the isolation connected at both sides.

Remedy: Potential compensation line

## 2.9 General data

### Conformity and approval

Conformity		
CE	2006/95/EG	Low-voltage directive
	2004/108/EG	EMC directive
Approval		
UL	UL 508	Approval for USA and Canada
others		
RoHS	2011/65/EU	Product is lead-free; Restriction of the use of certain hazardous substances in electrical and electronic equipment

### Protection of persons and device protection

Type of protection	-	IP20
Electrical isolation		
to the field bus	-	electrically isolated
to the process level	-	electrically isolated
Insulation resistance		-
Insulation voltage to reference earth		
Inputs / outputs	-	AC / DC 50V, test voltage AC 500V
Protective measures	-	against short circuit

### Environmental conditions to EN 61131-2

Climatic		
Storage / transport	EN 60068-2-14	-25...+70°C
Operation		
Horizontal installation	EN 61131-2	0...+60°C
Vertical installation	EN 61131-2	0...+60°C
Air humidity	EN 60068-2-30	RH1 (without condensation, rel. humidity 10... 95%)
Pollution	EN 61131-2	Degree of pollution 2
Mechanical		
Oscillation	EN 60068-2-6	1g, 9Hz ... 150Hz
Shock	EN 60068-2-27	15g, 11ms

General data

Mounting conditions		
Mounting place	-	In the control cabinet
Mounting position	-	Horizontal and vertical

EMC	Standard	Comment	
Emitted interference	EN 61000-6-4	Class A (Industrial area)	
Noise immunity zone B	EN 61000-6-2	Industrial area	
		EN 61000-4-2	ESD 8kV at air discharge (degree of severity 3), 4kV at contact discharge (degree of severity 2)
		EN 61000-4-3	HF irradiation (casing) 80MHz ... 1000MHz, 10V/m, 80% AM (1kHz) 1.4GHz ... 2.0GHz, 3V/m, 80% AM (1kHz) 2GHz ... 2.7GHz, 1V/m, 80% AM (1kHz)
		EN 61000-4-6	HF conducted 150kHz ... 80MHz, 10V, 80% AM (1kHz)
		EN 61000-4-4	Burst, degree of severity 3
		EN 61000-4-5	Surge, installation class 3 *

\*) Due to the high-energetic single pulses with Surge an appropriate external protective circuit with lightning protection elements like conductors for lightning and overvoltage is necessary.

## 3 Hardware description

### 3.1 Properties

#### Features

- Ethernet coupler with ModbusTCP protocol for max. 64 peripheral modules
- I/O access via up-to 8 stations
- Online parameterization via integrated Web server
- RJ45 jack 100BaseTX, 10BaseTX
- Automatic polarity and speed recognition (auto negotiation)
- Automatic recognition of parallel or crossed cable (auto crossover)
- Network LEDs for link/activity and speed
- Status LEDs for Ready and Error

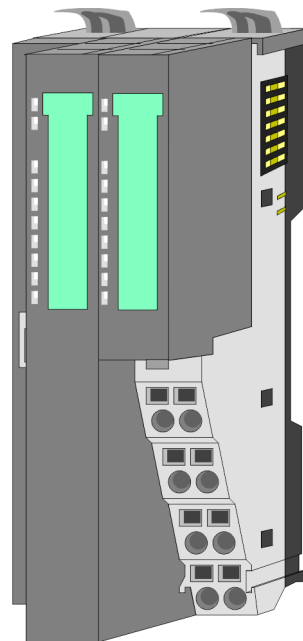

#### Order data

Type	Order number	Description
IM 053MT	053-1MT00	ModbusTCP Ethernet coupler for System SLIO

### 3.2 Structure

#### 053-1MT00

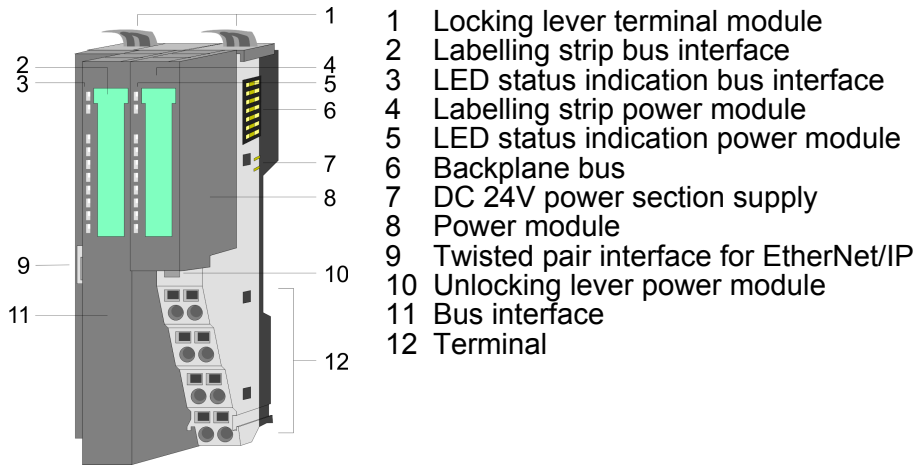

#### 3.2.1 Interfaces

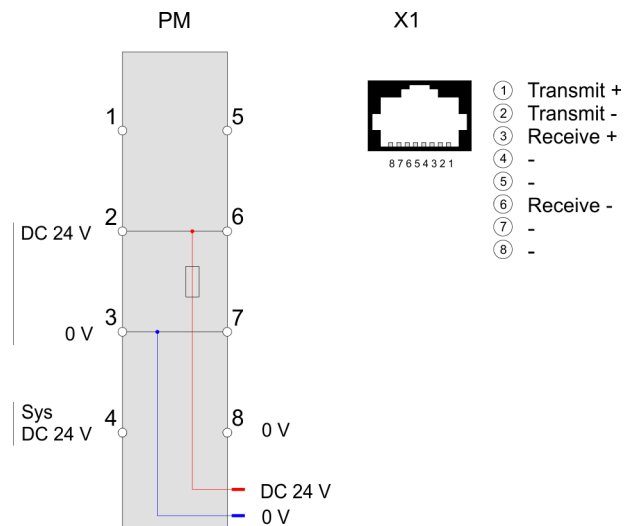

**CAUTION!**  
 Bus interface and power module of the bus coupler may not be separated!  
 Here you may only exchange the electronic module!



**Terminal**

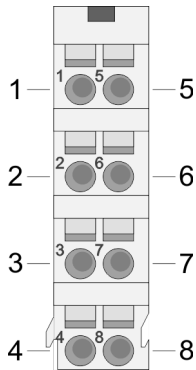

For wires with a core cross-section of 0.08mm<sup>2</sup> up to 1.5mm<sup>2</sup>.

Pos.	Function	Type	Description
1	---	---	not connected
2	DC 24V	I	DC 24V for power section supply
3	0V	I	GND for power section supply
4	Sys DC 24V	I	DC 24V for electronic section supply
5	---	---	not connected
6	DC 24V	I	DC 24V for power section supply
7	0V	I	GND for power section supply
8	Sys 0V	I	GND for electronic section supply

I: Input

**RJ45 jack bus interface X1**

8pin RJ45 jack

The RJ45 jack serves as interface for connecting to Ethernet. So that you can access the System SLIO modules with ModbusTCP, you have to assign valid IP address data to the Ethernet coupler.  
 ↪ 'Changing the IP address' on page 41

**3.2.2 LEDs**

**Bus interface**

PWR	SF	RUN	MT	L/A	SPD	Status
green 	red 	green 	red 	green 	green 	
•	X	X	X	X	X	The Ethernet coupler is power supplied.
•	○	•	X	•	X	The Ethernet coupler communicates via Ethernet ■ no errors.
•	X	B1	X •	X	X	BASP is activated (Time-out Ethernet communication)
•	X	X	X	○	○	There is no physical connection to Ethernet.
•	•	○	X	X	X	Error Ethernet communication ■ IP address error ■ error in the DHCP settings ■ faulty module plugged
•	B2	○	X	X	X	Error on the System SLIO bus ■ Error on the System SLIO bus
•	B3	○	X	X	X	Error on the System SLIO bus ■ Error in the parameterization

Technical data

PWR	SF	RUN	MT	L/A	SPD	Status
●	X	X	B1	X	X	Ethernet coupler is localized Identification was initialized by user and lasts for 10s.
●	○	X	B1	X	X	Firmware update was initialized by user.
●	○	○	X	X	X	Firmware update is finished, execute a PowerOFF-ON.
●	X	X	X	●	●	Speed: 100MBit/s
●	X	X	X	●	○	Speed: 10MBit/s

on: ● | off: ○ | not relevant: X

Blinking code B1 at a period duration of 1s: ○○●●

Blinking code B2 at a period duration of 1s: ●●●○

Blinking code B3 at a period duration of 1s: ○○○●

LEDs power module

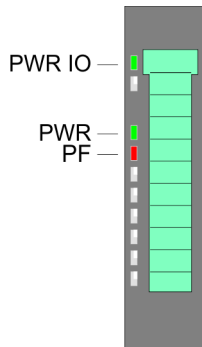

PWR IO	PWR	PF	Description
green	green	red	
●	X	○	Power section supply OK
●	●	○	Electronic section supply OK
X	X	●	Fuse electronic section supply defective

on: ● | off: ○ | not relevant: X

3.3 Technical data

<b>Order no.</b>	<b>053-1MT00</b>
Type	IM 053MT
Module ID	-
<b>Technical data power supply</b>	
Power supply (rated value)	DC 24 V
Power supply (permitted range)	DC 20.4...28.8 V
Reverse polarity protection	✓
Current consumption (no-load operation)	95 mA
Current consumption (rated value)	0.95 A
Inrush current	3.9 A
I²t	0.14 A²s
Max. current drain at backplane bus	3 A
Max. current drain load supply	10 A

<b>Order no.</b>	<b>053-1MT00</b>
Power loss	3 W
<b>Status information, alarms, diagnostics</b>	
Status display	yes
Interrupts	yes, parameterizable
Process alarm	yes, parameterizable
Diagnostic interrupt	yes, parameterizable
Diagnostic functions	yes, parameterizable
Diagnostics information read-out	possible
Supply voltage display	green LED
Service Indicator	yellow LED
Group error display	red SF LED
Channel error display	none
<b>Hardware configuration</b>	
Racks, max.	1
Modules per rack, max.	64
Number of digital modules, max.	64
Number of analog modules, max.	64
<b>Communication</b>	
Fieldbus	Modbus / TCP/IP
Type of interface	Ethernet 10/100 MBit
Connector	RJ45
Topology	-
Electrically isolated	✓
Number of participants, max.	-
Node addresses	-
Transmission speed, min.	10 Mbit/s
Transmission speed, max.	100 Mbit/s
Address range inputs, max.	1 KB
Address range outputs, max.	1 KB
Number of TxPDOs, max.	-
Number of RxPDOs, max.	-
<b>Housing</b>	
Material	PPE / PPE GF10
Mounting	Profile rail 35 mm
<b>Mechanical data</b>	
Dimensions (WxHxD)	48.5 mm x 109 mm x 76.5 mm

## Technical data

<b>Order no.</b>	<b>053-1MT00</b>
Weight	155 g
<b>Environmental conditions</b>	
Operating temperature	0 °C to 60 °C
Storage temperature	-25 °C to 70 °C
<b>Certifications</b>	
UL508 certification	yes

## 4 Deployment

### 4.1 Basics

#### General

Typical field bus systems are divided into master and slave systems. Master systems are CPUs, coupled to a CPU, allowing remote programming res. visualization of the according CPU as well as the data transfer between several TCP/IP participants. Slave systems on the other hand are "data collectors" that deliver the I/O data of the connected modules to the requesting master. The Ethernet coupler described in this chapter is a slave system. For the communication happens via TCP/IP, the slave system is referred to as server and a master as client. The Ethernet coupler from VIPA allows you to connect up to 64 modules of your System SLIO via Ethernet. Up to 8 clients may communicate simultaneously with the Ethernet coupler.

#### Automatic address mapping

After startup of the Ethernet coupler the modules connected to the backplane bus are determined and mapped to his address area. With address mapping there is an area for input and an area for output data. Using the integrated Web server, you have access to the current mapping. Here you can also parameterize your modules.

#### Communication

The Ethernet coupler is connected with the modules via the backplane bus. It collects their data and places this as "server" (slave) at the disposal of the superordinated "client" (master system). The communication happens via TCP/IP with leading ModbusTCP protocol. Vice versa, the Ethernet coupler receives the data, addressed to it by IP address and port, and transfers it to its output periphery.

#### Protocols

Protocols define rules or standards for communication. The so called ISO/OSI layer model is generally accepted for the standardization of computer communication. The layer model is based upon seven layers with guidelines for the deployment of hard- and software.

Layer	Function	Protocol
Layer 7	Application Layer (application)	Modbus TCP
Layer 6	Presentation Layer (presentation)	
Layer 5	Session Layer (session)	
Layer 4	Transport Layer (transport)	TCP
Layer 3	Network Layer (network)	IP
Layer 2	Data Link Layer (security)	
Layer 1	Physical Layer (bit transfer)	

#### Telegram structure

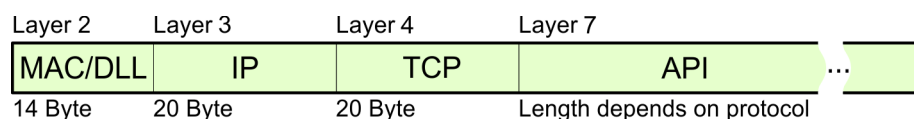

**MAC/DLL**

While the Ethernet physics covers with its standard signal levels Layer 1, MAC/DLL covers the conditions of the security layer (Layer 2). With MAC (**M**edium **A**ccess **C**ontrol) / DLL (**D**ata **L**ink **L**ayer) the communication happens at the lowest Ethernet level using MAC addresses. Every Ethernet communication participant has a MAC address that must be unique at the network. The deployment of MAC addresses specifies source and destination unambiguously.

**IP**

The Internet Protocol covers the network layer (layer 3) of the ISO/OSI layer model. The main purpose of IP is to send data packages from one station to another, passing several other stations. This data packages are referred to as datagrams. The IP does neither serve the according sequence nor the deliverance at the receiver. For the unambiguous distinction between sender and receiver, 32bit addresses are used (IP addresses) that are normally written in four octets of each 8bit, e.g. 172.16.192.11. One octet may represent numbers between 0 and 255. A part of the address specifies the network, the rest identifies the single stations in the network. The proportions of network part and station part is floating and depends on the network size.

**TCP**

The TCP (**T**ransmission **C**ontrol **P**rotocol) puts directly upon the IP and covers therefore the transport layer (layer 4) of the ISO/OSI layer model. TCP is a connection orientated end-to-end protocol and serves the logical connection between two partners. TCP ensures the sequential correct and reliable data transfer. Every datagram is preceded by a header of at least 20 octets that contains, among others, the serial number for the according sequence. This causes that within a network, the single datagrams may reach their destination on different ways.

**API**

API means **A**pplication **P**rogramming **I**nterface. API covers the conditions of the Application Layer (Layer 7). Here, the header and user data of the according protocols are stored. The Ethernet coupler uses the ModbusTCP protocol, described further below.

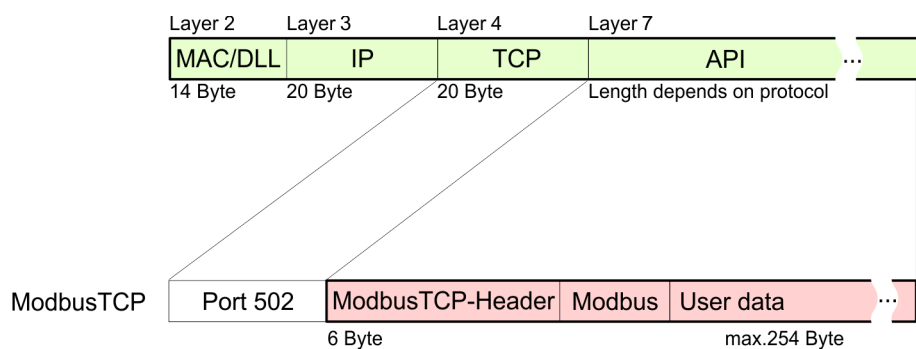

**Modbus/TCP**

ModbusTCP is a Modbus-RTU protocol, put upon TCP/IP. The Modbus protocol is a communication protocol supporting a hierarchic structure with one master and several slaves. ModbusTCP extends Modbus to a client server communication where several client may access a server. For the addressing happens by means of the IP addresses, the address integrated in the Modbus telegram irrelevant. Furthermore, the check sum is not required because the sequence insurance happens via TCP/IP. After the request of a client, this awaits the answer of the server for a configurable time. ModbusTCP exclusively uses the RTU format. Every byte is transferred as one

sign. This enables a higher data pass-through than the Modbus-ASCII format. The RTU time supervision is omitted for the header contains the size of the telegram length to be received. Data that are transferred via ModbusTCP may contain bit and word information. At bit chains, the highest bit is send first, i.e. in a word it is at the most left position. At words, the highest byte is send first. The access to a Modbus slave happens via function codes that are described in detail in this chapter further below.

## 4.2 Access to the Ethernet coupler

### 4.2.1 Overview

The following illustration shows the Ethernet coupler access possibilities.

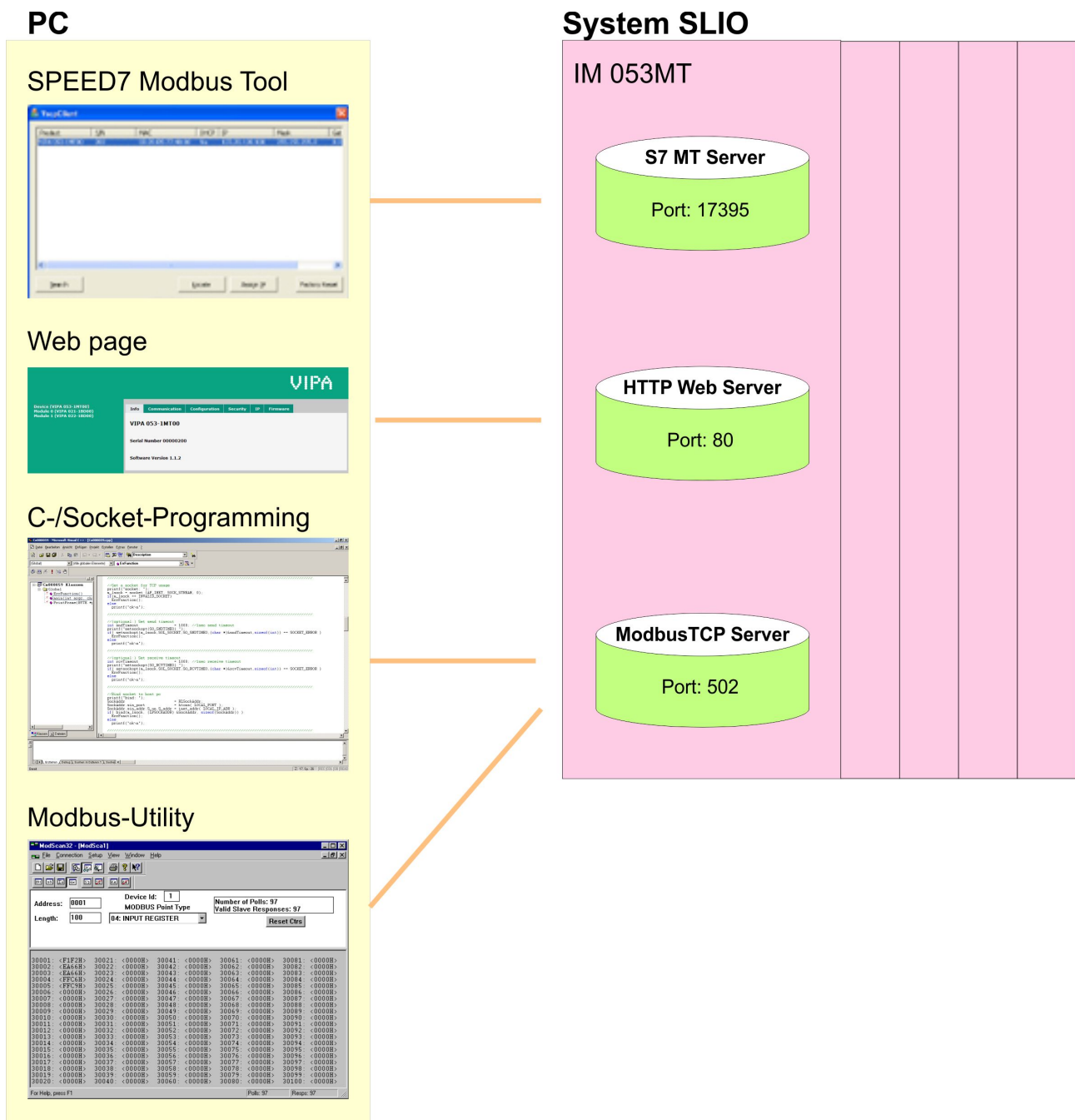

## 4.2.2 SPEED7 Modbus Tool

The *SPEED7 Modbus Tool* may be found in the service area of [www.vipa.com](http://www.vipa.com). Load and execute this program. With the *SPEED7 Modbus Tool* the Ethernet coupler may be identified within the network, assigned with IP address data or reset to factory settings. In the following these functions are more described.

### Searching the Ethernet coupler

Every Ethernet coupler, which was found in the local network by means of a broadcast, is listed. With several Ethernet coupler in the system the search may be limited by product name, serial number or MAC address.

### Localizing the Ethernet coupler

With [Locate] a listed Ethernet coupler may be localized. During the localization the MT LED flashes for 10s on the corresponding Ethernet coupler for clear identification.

### IP address assignment

With [Assign IP] you may assign to a listed Ethernet coupler IP address data. You get valid IP address parameters from your system administrator.

### Factory reset

A factory reset is only possible during the localization within 10s and takes place with the following approach:

1. ► Chose from the search list of Ethernet couplers the Ethernet coupler, which is to be reset to factory settings.
2. ► Click at [Locate].
  - ⇒ The MT LED of the corresponding Ethernet coupler flashes.
3. ► For the factory reset now you have to click at [Factory RESET] within 10s.
  - ⇒ The Ethernet coupler is reset to factory settings.

#### Delivery state

- Password and module parameter are deleted
- IP address: 10.0.0.1
- Subnet mask: 255.255.255.0

## 4.2.3 Web page

### 4.2.3.1 Access

#### Delivery state

On delivery the Modbus/TCP coupler has the following settings:

- Password and module parameter are deleted
- IP address: 10.0.0.1
- Subnet mask 255.255.255.0



### Changing the IP address

To change the IP address you have the following possibilities:

- Changing by means of the *SPEED7 Modbus Tool*  
 ↳ *Chapter 4.2.2 'SPEED7 Modbus Tool' on page 40*
- By shortly changing the IP address of the PC network card (described below).

To change the IP address of the Modbus/TCP coupler the communicating systems must be in the same IP circuit. For this you have to shortly change the IP address of your PC network card. Please consider that this is only possible as a user with administrative rights. Otherwise, contact your system administrator. The adaptation happens with the following proceeding:

1. ➤ Connect your Modbus/TCP coupler via Ethernet with the network card of your PC and switch-on the power supply of the Modbus/TCP coupler.
2. ➤ Call the 'Network setting' of the 'Control Panel'.
3. ➤ Open the 'Properties' of your network adapter and open the properties dialog of 'Internet protocol TCP/IP...'
4. ➤ Write down the IP address settings.
5. ➤ Now enter an IP address, which differs in the last number of 10.0.0.1 such as 10.0.0.2 and the subnet mask 255.255.255.0. If IP address data just exist, you can add the new as additional data.
6. ➤ Confirm your input and close all the dialogs.
  - ⇒ Now you can access the web server of the Modbus/TCP coupler. Here you have the possibility to change the IP address data via the register 'IP'.
7. ➤ Open, after you have adjusted the IP address data at the Modbus/TCP coupler via the web server, on your PC the properties dialog of 'Internet protocol TCP/IP...' again, enter the original IP address data, confirm your entries and close all the dialogs.
  - ⇒ If the systems are in the same IP circle, you can access the web server of the Modbus/TCP coupler.

#### 4.2.3.2 Structure of the Web page

The web page is built dynamically and depends on the number of modules, which are connected to the Ethernet coupler.



- 1 Module list: Ethernet coupler and System SLIO modules in installed order
- 2 Functions for the module selected in the *module list*
- 3 Information respectively input area of the corresponding function

Access to the Ethernet coupler > Web page

#### 4.2.3.3 Web page of the selected Ethernet coupler



#### Info

Here order number, serial number and firmware version of the Ethernet coupler are listed.

#### Communication

As soon as the Ethernet cable is pulled with enabled "Check cable", the communication is finished, all the modules are disabled (BASP active) and this is indicated with flashing RUN LED by the Ethernet coupler. At "Communication timeout" you can specify a timeout value for Ethernet communication in ms. As soon as the Ethernet cable is pulled with enabled "Check cable", the communication is finished, all the modules are disabled (BASP active) and this is indicated with flashing RUN LED by the Ethernet coupler.

#### Configuration

Each system SLIO module has an unique identification number - module ID. The modules are listed on the web page by means of their module ID. As soon as a module is configured, the ID of the corresponding module is listed. In this dialog field you have the possibility to store the current module configuration or to import a module configuration. With [Delete] the parameterization of all the modules may be deleted in the Ethernet coupler.

- **Export Station Configuration**  
With [Save] a window is opened and shows the configuration as XML. Select '*File* → *Save as*' and save the current configuration as XML file.
- **Import Station and Modules Configuration**  
Select with [Search...] the according XML file and load this with [Load]. While loading the parameters of the Ethernet coupler and the modules are loaded.
- **Import Modules Configuration**  
Select with [Search...] the according XML file and load this with [Load]. While loading only the parameters of the modules are loaded. The parameters of the Ethernet coupler further exist.
- **Save Configuration of all Modules**  
With [Save] the current configuration is stored in the Ethernet coupler. If the current module ID deviates from the just configured module ID after a system start-up, the Ethernet coupler does not go into RUN and shows the error on its web page.
- **Delete Configuration of all Modules**  
With [Delete] the configuration in the Ethernet coupler may be deleted.



Only there is a configuration for a module, this may be used to check preset and current configuration. If the current configuration differs from the preset (e.g. module was removed) the system reports an error and does not go to RUN. If there is no preset module configuration and the current configuration is changed during operation, the Ethernet coupler performs a restart and switches again to RUN.

- Security  
All functions for the writing access to the Ethernet coupler can be secured by a password.
- IP  
Here you may assign to your Ethernet coupler IP address data. For valid IP address data please contact your system administrator. On delivery the Ethernet coupler has the following IP address parameters:
  - IP address: 10.0.0.1
  - Subnet mask: 255.255.255.0
- Firmware  
With this function you can bring in a firmware update. You can get the appropriate firmware file from VIPA.

#### 4.2.3.4 Web page with selected module

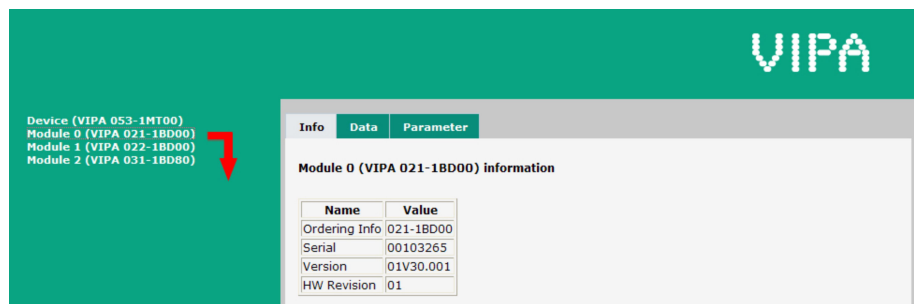

**Info** Here order number, serial number and firmware version of the according module are listed.

**Data** At *Data* the states of the inputs respectively outputs are listed. In addition, you can directly control the outputs of the corresponding module.

**Parameter** If available the parameter data of the corresponding module may be shown and changed if necessary.

#### 4.2.4 C-/Socket programming

The ModbusTCP server is accessed via port 502. Via simple C programs it is possible to transfer data between PC and Ethernet coupler with ModbusTCP. For the deployment of the Ethernet couplers at a PC you should have a thorough knowledge in C programming, especially in socket programming. In the following the steps of programming are shown.

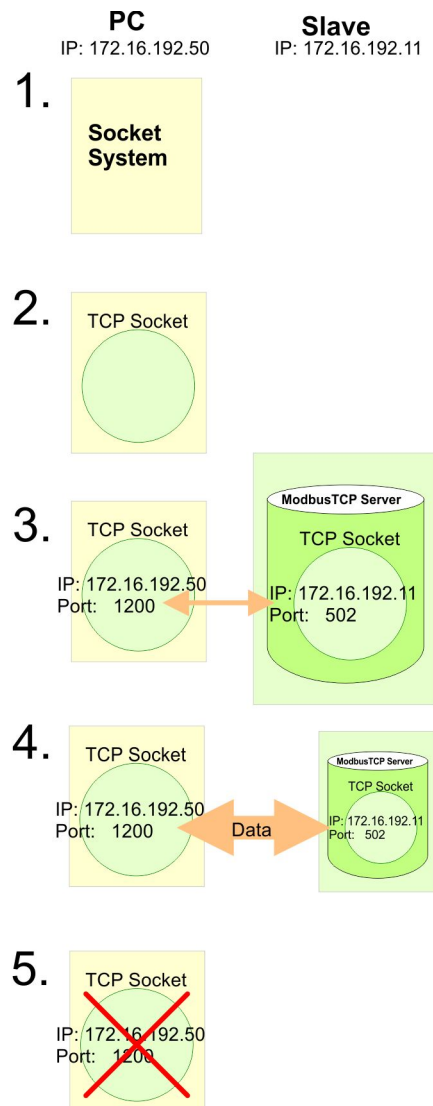

#### 1. Start Microsoft Socket System

```
⇒ WSASStartup (wVersionRequested, &wsaData);
```

#### 2. Reserve Socket resources for TCP

```
⇒ m_lsock = socket (AF_INET, SOCK_STREAM, 0);
```

#### 3. Establish connection to external device

```
⇒ SockAddr.sin_port = htons
(m_wPort); SockAddr.sin_addr.S_un.S_addr =
inet_addr(m_szIpAddress); connect(m_lsock,
(LPSOCKADDR) &SockAddr, sizeof(SockAddr));
```

- 4. For write res. read access you have to build up telegrams according to the protocol and store them in `sndBuf`. `sndBufLen` contains the number of bytes to be sent.

↓↑	Read access	
	Send <code>sndBuf</code> (Request)	<code>send(m_lsock, (char *)sndBuf, sndBufLen, 0);</code>
	Receive telegram in <code>rcvBuf</code> (Response +data)	<code>recv(m_lsock, (char *)rcvBuf, sizeof(rcvBuf), 0);</code>
	Write access	
	Send <code>sndBuf</code> (Request+data)	<code>send(m_lsock, (char *)sndBuf, sndBufLen, 0);</code>
	Receive telegram in <code>rcvBuf</code> (Response)	<code>recv(m_lsock, (char *)rcvBuf, sizeof(rcvBuf), 0);</code>

- 5. Close socket again  
 ⇒ `closesocket(m_lsock);`

### 4.2.5 Modbus utility

The access is via port 502 at the ModbusTCP Server. Modbus utility means all tools and programs that have a ModbusTCP interface. For example, you may find the demo tool "ModbusScan32" from WinTech for download at [www.win-tech.com](http://www.win-tech.com).

## 4.3 Accessing the System SLIO

### 4.3.1 Overview

So that you can access the System SLIO modules with ModbusTCP, you have to assign valid IP address data to the Ethernet coupler.  
 ↪ 'Changing the IP address' on page 41

In the following you will find the description of accessing the following System SLIO areas via ModbusTCP.

- I/O area
- Parameter data
- Diagnostics data

Information concerning the allocation areas may be found in the description of the corresponding System SLIO module.



**Usage of the modules 040-1BA00 respectively 040-1CA00**

Depending on the system you may use a maximum of 16 System SLIO modules of the type 040-1xA00. Otherwise, this could cause bus errors!



Please consider the System SLIO power and clamp modules do not have any module ID. These may not be recognized by the Ethernet coupler and so are not listed and considered during slot allocation. Further within ModbusTCP the slots are designated as ModbusTCP-Slot. The counting always begins with 0.

### 4.3.2 Address-Mapping

To individually call the connected peripheral modules, certain addresses in the Ethernet coupler have to be assigned to them. For input and output area, the Ethernet coupler has an address range of each 1024byte. The address allocation (also called mapping) happens automatically and may not be influenced. The mapping may be seen via the website of the coupler.

#### Rules

At boot-up, the Ethernet coupler assigns automatically addresses for its in-/ output periphery following this rules:

- All modules are mapped from left (Ethernet coupler) to right in ascending sequence starting with address 0.
- It is separated between in- and output area (if a module has in- and output data, these are stored at different addresses).
- There is no separation between digital and analog data. The Ethernet coupler creates coherent areas for in- and output data.



A description of the in- and output areas that are occupied by a module is to find in the concerning module description. Please regard that modules that are occupying more than 1byte like e.g. analog modules, are automatically stored starting with an even address.

#### Example

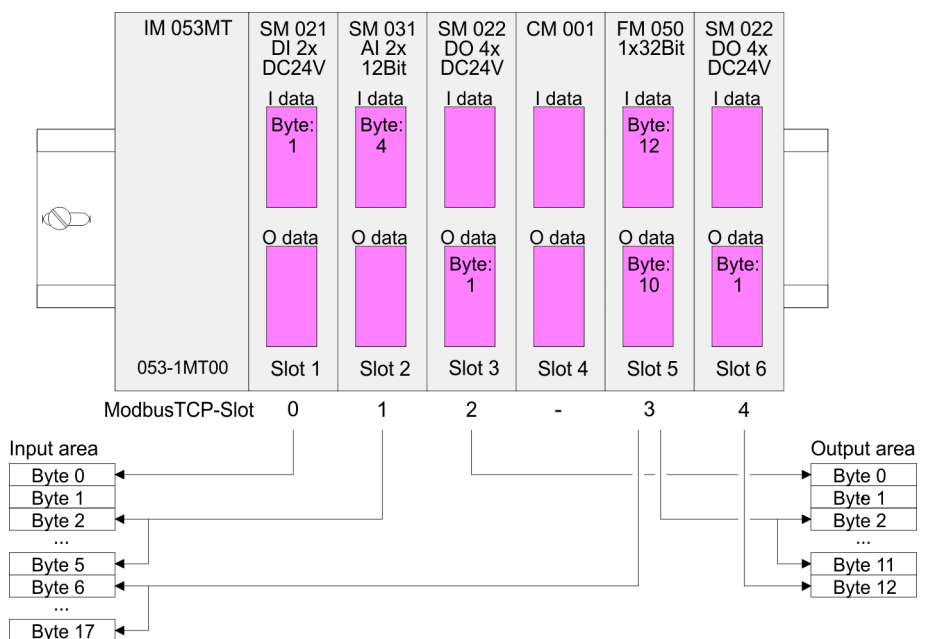

### 4.3.3 Accessing I/O area

Normally the access with Modbus happens by means of the ranges 0x, 1x, 3x and 4x. 0x and 1x gives you access to digital bit areas and 3x and 4x to analog word areas. For the Ethernet coupler from VIPA is not differentiating digital and analog data, the following assignment is valid:

- 0x - Bit area for master output  
Access via function code 01h, 05h, 0Fh
- 1x - Bit area for master input  
Access via function code 02h
- 3x - Word area for master input  
Access via function code 04h, 17h
- 4x - Word area for master output  
Access via function code 03h, 06h, 10h, 16h, 17h

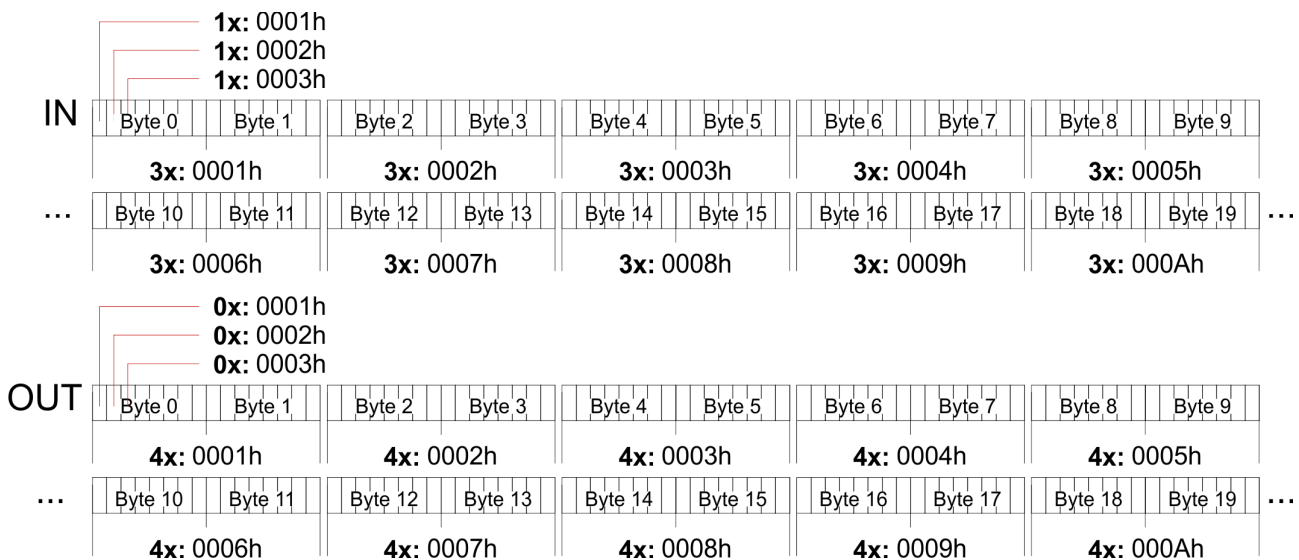

### 4.3.4 Accessing parameter data

With the first start-up modules, which were parameterizable, operate with their default parameters. If you want to change parameters the Ethernet coupler respectively the corresponding modules may be parameterized via the integrated Web page. Here by means of the corresponding *ModbusTCP-Slot* parameter may be viewed and changed.

### 4.3.5 Accessing diagnostics data

If configured System SLIO modules provide interrupt data on failure. As soon as one or more modules report an interrupt, the interrupt data of the appropriate slot location is received and acknowledged by the Ethernet coupler. After that the bit assigned to the *ModbusTCP-Slot* is set in the internal *alarm information* image and the corresponding interrupt data are stored. In System SLIO we distinguish between *hardware interrupt* and *diagnostic interrupt*. To distinguish there is a 64bit wide field (bit 0 = *ModbusTCP-Slot* 0 to bit 63 = *Mod-*

*busTCP-Slot 63*) in the diagnostic image each for hardware and diagnostics interrupt. Then for each slot 16byte hardware interrupt data or 32byte diagnostics interrupt data are following To acknowledge the diagnostics and hardware interrupt status may be write accessed. The alarm data may only be read.

## Register allocation

Address	Access on
0x/1x: 4000h ... 403Fh	Bit access to hardware interrupt state: 0x/1x: 4000: Hardware interrupt state ModbusTCP-Slot 0 0x/1x: 4001: Hardware interrupt state ModbusTCP-Slot 1 ... 0x/1x: 403F: Hardware interrupt state ModbusTCP-Slot 63
0x/1x: 5000h ... 503Fh	Bit access to diagnostics interrupt state: 0x/1x: 5000: Diagnostics interrupt state ModbusTCP-Slot 0 0x/1x: 5001: Diagnostics interrupt state ModbusTCP-Slot 1 ... 0x/1x: 503F: Diagnostics interrupt state ModbusTCP-Slot 63
3x: 4000h ... 41FFh	Word access to hardware interrupt data: 3x: 4000h ... 4007h: ModbusTCP-Slot 0 3x: 4008h ... 400Fh: ModbusTCP-Slot 1 ... 3x: 41F8h ... 41FFh: ModbusTCP-Slot 63
3x: 4000h ... 4007h	16byte hardware interrupt state ModbusTCP-Slot 0
3x: 4008h ... 400Fh	16byte hardware interrupt state ModbusTCP-Slot 1
3x: 4010h ... 4017h	16byte hardware interrupt state ModbusTCP-Slot 2
...	...
3x: 41F8h ... 41FFh	16byte hardware interrupt state ModbusTCP-Slot 63
3x: 5000h ... 500Fh	32byte diagnostics data from ModbusTCP-Slot 0
3x: 5010h ... 501Fh	32byte diagnostics data from ModbusTCP-Slot 1
...	...
3x: 53F0h ... 53FFh	32byte diagnostics data from ModbusTCP-Slot 63

## 4.4 Modbus/TCP

### General

Modbus/TCP is a Modbus protocol put upon TCP/IP, where the IP address serves the addressing. Modbus/TCP allows a client-server-communication, several clients may be provided from one server.

### Telegram structure incl. TCP/IP

The request telegrams sent by a master and the respond telegrams of the slave have the same structure:



ModbusTCP	Slave address	Function code	Data
6byteHeader with number of following bytes	1byte data	1byte data	max. 254byte

**Modbus/TCP header (6byte)**

For send and receive telegrams, Modbus/TCP uses a header of 6byte with the following structure:

Byte	Name	Description
0	Transaction identifier (High byte)	Is sent back by the server (user-defined)
1	Transaction identifier (Low byte)	Is sent back by the server (user-defined)
2	Protocol identifier (High byte)	Always 0
3	Protocol identifier (Low byte)	Always 0
4	Length field (High byte)	Always 0 because messages < 256byte
5	Length field (Low byte)	Number of following bytes

Normally, byte 0 ... 4 have the value 0. You may also increase byte 0 and 1 in the slave and thus establish an additional control.

**4.5 Modbus function codes**

**Naming convention**

Modbus has some naming conventions:

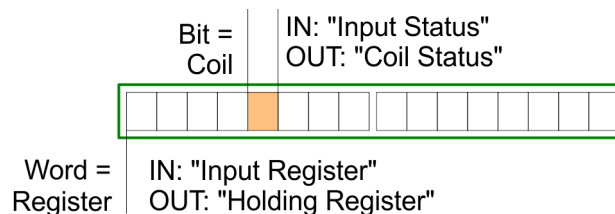

- Modbus differentiates between bit and word access; Bits = "Coils" and Words = "Register".
- Bit inputs are referred to as "Input-Status" and bit outputs as "Coil-Status".
- Word inputs are referred to as "Input-Register" and word outputs as "Holding-Register".

**Range definitions**

Normally the access with Modbus happens by means of the ranges 0x, 1x, 3x and 4x.

0x and 1x gives you access to *digital* bit areas and 3x and 4x to *analog* word areas.

For the Ethernet coupler from VIPA is not differentiating digital and analog data, the following assignment is valid:

- 0x - Bit area for master output  
Access via function code 01h, 05h, 0Fh
- 1x - Bit area for master input  
Access via function code 02h
- 3x - Word area for master input  
Access via function code 04h, 17h
- 4x - Word area for master output  
Access via function code 03h, 06h, 10h, 16h, 17h

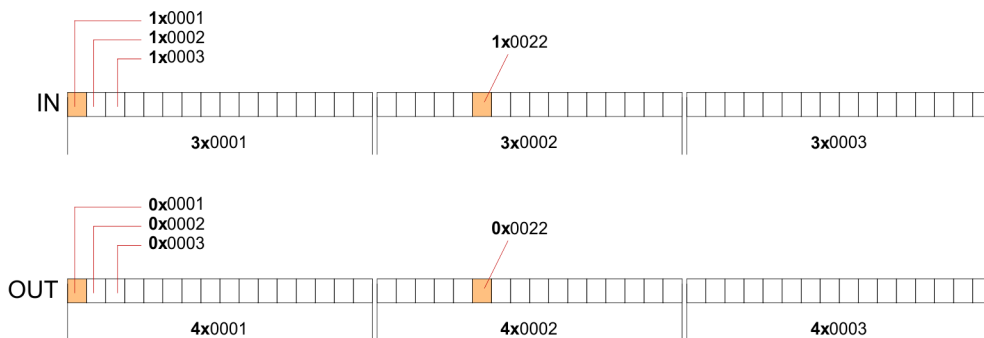

**Overview**

With the following Modbus function codes a Modbus master can access a Modbus slave. The description always takes place from the point of view of the master:

Code	Command	Description
01h	Read n Bits	Read n bits of master output area 0x
02h	Read n Bits	Read n bits of master input area 1x
03h	Read n Words	Read n words of master output area 4x
04h	Read n Words	Read n words master input area 3x
05h	Write 1 Bit	Write 1 bit to master output area 0x
06h	Write 1 Word	Write 1 word to master output area 4x
0Fh	Write n Bits	Write n bits to master area 0x
10h	Write n Words	Write n words to master area 4x
16h	Mask 1 Word	Mask 1 word in master output area 4x
17h	Write n Words and Read m Words	Write n words into master output area 4x and the respond contains m read words of the master input area 3x

**Byte sequence in a word**

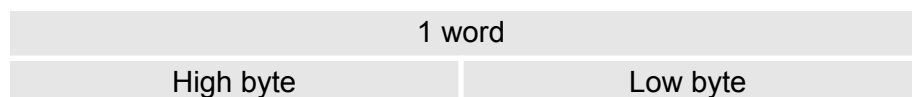

**Respond of the coupler** If the slave announces an error, the function code is sent back with a "OR" and 80h. Without an error, the function code is sent back.

Coupler answer: Function code OR 80h → Error & error number  
 Function code → OK

If the slave announces an error, the function code is sent back with a "OR" and 80h. Without an error, the function code is sent back.

- 01h: Function number is not supported
- 02h: Addressing errors
- 03h: Data errors
- 04h: System SLIO bus is not initialized
- 07h: General error

**Read n Bits 01h, 02h** Code 01h: Read n bits of master output area 0x.  
 Code 02h: Read n bits of master input area 1x.

**Command telegram**

Modbus/TCP-Header						Slave address	Function code	Address1. bit	Number of bits
x	x	0	0	0	6				
6byte						1byte	1byte	1word	1word

**Respond telegram**

Modbus/TCP-Header						Slave address	Function code	Number of read bytes	Data 1. byte	Data 2. byte	...
x	x	0	0	0							
6byte						1byte	1byte	1byte	1byte	1byte	
									max. 252byte		

**Read n words 03h, 04h** 03h: Read n words of master output area 4x.

04h: Read n words master input area 3x.

**Command telegram**

Modbus/TCP-Header						Slave address	Function code	Address word	Number of words
x	x	0	0	0	6				
6byte						1byte	1byte	1word	1word

**Respond telegram**

Modbus/TCP-Header						Slave address	Function code	Number of read bytes	Data 1. word	Data 2. word	...
x	x	0	0	0							
6byte						1byte	1byte	1byte	1word	1word	
									max. 126words		

**Write 1 bit 05h**

Code 05h: Write 1 bit to master output area 0x.

A status change is via "Status bit" with following values:

"Status bit" = 0000h → Bit = 0

"Status bit" = FF00h → Bit = 1

**Command telegram**

Modbus/TCP-Header						Slave address	Function code	Address bit	Status bit
x	x	0	0	0	6				
6byte						1byte	1byte	1word	1word

**Respond telegram**

Modbus/TCP-Header						Slave address	Function code	Address bit	Status bit
x	x	0	0	0	6				
6byte						1byte	1byte	1word	1word

**Write 1 word 06h**

Code 06h: Write 1 word to master output area 4x.

**Command telegram**

Modbus/TCP-Header						Slave address	Function code	Address word	Value word
x	x	0	0	0	6				
6byte						1byte	1byte	1word	1word

**Respond telegram**

Modbus/TCP-Header						Slave address	Function code	Address word	Value word
x	x	0	0	0	6				
6Bbyte						1byte	1byte	1word	1word

**Write n bits 0Fh**

Code 0Fh: Write n bits to master output area 0x.

Please regard that the number of bits are additionally to be set in byte.

**Command telegram**

Modbus/TCP-Header						Slave address	Function code	Address 1. bit	Number of bits	Number of bytes	Data 1. byte	Data 2. byte	...
x	x	0	0	0									
6byte						1byte	1byte	1word	1word	1byte	1byte	1byte	1byte
											max. 248byte		

**Respond telegram**

Modbus/TCP-Header						Slave address	Function code	Address 1. bit	Number of bits
x	x	0	0	0	6				
6byte						1byte	1byte	1word	1word

**Write n words 10h**

Code 10h: Write n words to master output area 4x.

**Command telegram**

Modbus/TCP-Header						Slave address	Function code	Address 1. word	Number of words	Number of bytes	Data 1. word	Data 2. word	...
x	x	0	0	0									

Modbus function codes

6byte	1byte	1byte	1word	1word	1word	1word	1word	1word	
							max. 124byte		

**Respond telegram**

Modbus/TCP-Header						Slave address	Function code	Address 1. word	Number of words
x	x	0	0	0	6				
6byte						1byte	1byte	1word	1word

**Mask a word 16h**

Code 16h: This function allows to mask a word in the master output area 4x.

**Command telegram**

Modbus/TCP-Header						Slave address	Function code	Address word	AND Mask	OR Mask
x	x	0	0	0	8					
6byte						1byte	1byte	1word	1word	1word

**Respond telegram**

Modbus/TCP-Header						Slave address	Function code	Address word	AND Mask	OR Mask
x	x	0	0	0	8					
6byte						1byte	1byte	1word	1word	1word

**Write n words and Read m words 17h**

Code 17h: This function allows to write n words to the master output area 4x and read m words from the master input area 3x with one request.

**Command telegram**

Modbus/TCP-Header						Slave address	Function code	Read address	Read number words	Write address	Write number words	Write number bytes	Write Data 1.word	Write Data 2.word	...
x	x	0	0	0											
6byte						1byte	1byte	1Wort	1Wort	1word	1word	1byte	1word	1word	
												max. 122words			

**Respond telegram**

Modbus/TCP-Header						Slave address	Function code	Read number bytes	Read Data 1. word	Read Data 2. word	...
x	x	0	0	0							

6byte	1byte	1byte	1byte	1word	1word	
				max. 126words		

## 4.6 Register allocation

### I/O data

Address	Access to
1x: 0001h ... 2000h	Bit access to input area
3x: 0001h ... 0200h	Word access to input area
0x: 0001h ... 2000h	Bit access to output area
4x: 0001h ... 0200h	Word access to output area

### Diagnostics

Address	Access to
0x/1x: 4000h ... 403Fh	Bit access to hardware interrupt state: 0x/1x: 4000: Hardware interrupt state ModbusTCP-Slot 0 0x/1x: 4001: Hardware interrupt state ModbusTCP-Slot 1 ... 0x/1x: 403F: Hardware interrupt state ModbusTCP-Slot 63
0x/1x: 5000h ... 503Fh	Bit access to diagnostics interrupt state: 0x/1x: 5000: Diagnostics interrupt state ModbusTCP-Slot 0 0x/1x: 5001: Diagnostics interrupt state ModbusTCP-Slot 1 ... 0x/1x: 503F: Diagnostics interrupt state ModbusTCP-Slot 63
3x: 4000h ... 41FFh	Word access to hardware interrupt data: 3x: 4000h ... 4007h: ModbusTCP-Slot 0 3x: 4008h ... 400Fh: ModbusTCP-Slot 1 ... 3x: 41F8h ... 41FFh: ModbusTCP-Slot 63
3x: 4000h ... 4007h	16byte hardware interrupt state ModbusTCP-Slot 0
3x: 4008h ... 400Fh	16byte hardware interrupt state ModbusTCP-Slot 1
3x: 4010h ... 4017h	16byte hardware interrupt state ModbusTCP-Slot 2
...	...
3x: 41F8h ... 41FFh	16byte hardware interrupt state ModbusTCP-Slot 63
3x: 5000h ... 500Fh	32byte diagnostics data from ModbusTCP-Slot 0

LED status indication

Address	Access to
3x: 5010h ... 501Fh	32byte diagnostics data from ModbusTCP-Slot 1
...	...
3x: 53F0h ... 53FFh	32byte diagnostics data from ModbusTCP-Slot 63

## 4.7 LED status indication

### General

The LEDs installed to display the status allow extensive diagnostics during the PowerON procedure as well as during operation. The result of the diagnosis is determined by the combination of the different LEDs and the current operating mode.

### Bus interface

PWR	SF	RUN	MT	L/A	SPD	Status
green 	red 	green 	red 	green 	green 	
●	X	X	X	X	X	The Ethernet coupler is power supplied.
●	○	●	X	●	X	The Ethernet coupler communicates via Ethernet ■ no errors.
●	X	B1	X ●	X	X	BASP is activated (Time-out Ethernet communication)
●	X	X	X	○	○	There is no physical connection to Ethernet.
●	●	○	X	X	X	Error Ethernet communication ■ IP address error ■ error in the DHCP settings ■ faulty module plugged
●	B2	○	X	X	X	Error on the System SLIO bus ■ Error on the System SLIO bus
●	B3	○	X	X	X	Error on the System SLIO bus ■ Error in the parameterization
●	X	X	B1	X	X	Ethernet coupler is localized Identification was initialized by user and lasts for 10s.
●	○	X	B1	X	X	Firmware update was initialized by user.
●	○	○	X	X	X	Firmware update is finished, execute a PowerOFF-ON.
●	X	X	X	●	●	Speed: 100MBit/s



LED status indication

PWR	SF	RUN	MT	L/A	SPD	Status
●	X	X	X	●	○	Speed: 10MBit/s

on: ● | off: ○ | not relevant: X

*Blinking code B1* at a period duration of 1s: ○○●●

*Blinking code B2* at a period duration of 1s: ●●●●○

*Blinking code B3* at a period duration of 1s: ○○○○●